

**OPERATION  
&  
MAINTENANCE  
MANUAL**

**Electronic Table - Top Autoclaves  
(With cooling option)  
Models  
2540, 3150, 3850, 3870, 5050, 5075 EL**





## TABLE OF CONTENT

PARAGRAPH	PAGE NO.
<b>1 GENERAL</b> .....	<b>4</b>
<b>1.1 Incoming Inspection</b> .....	<b>4</b>
<b>1.3 Warranty Statement</b> .....	<b>4</b>
<b>2 SAFETY INSTRUCTIONS</b> .....	<b>6</b>
<b>3 GENERAL INFORMATION</b> .....	<b>8</b>
<b>3.2 Stand – by heating mode</b> .....	<b>8</b>
<b>3.3 Operating Conditions</b> .....	<b>9</b>
<b>3.4 Utilities</b> .....	<b>9</b>
<b>3.5 Load on counter</b> .....	<b>9</b>
<b>3.6 Construction</b> .....	<b>9</b>
<b>3.7 Environment Emission Information</b> .....	<b>10</b>
<b>3.8 Directives and Standards</b> .....	<b>10</b>
<b>3.9 Electrical Data</b> .....	<b>10</b>
<b>3.10 Overall Dimensions Model 2540 EL</b> .....	<b>11</b>
<b>3.11 Overall Dimensions Models 3150 EL</b> .....	<b>12</b>
<b>3.12 Overall Dimensions Models 3850, 3870 EL</b> .....	<b>13</b>
<b>3.13 Overall Dimensions Models 5050, 5075 EL</b> .....	<b>14</b>
<b>3.14 Loading Capacities</b> .....	<b>15</b>
<b>3.15 Symbol Description</b> .....	<b>15</b>
<b>3.16 Technical Specifications EL</b> .....	<b>16</b>
<b>3.17 Water quality</b> .....	<b>17</b>
<b>4 STERILIZATION PROGRAMS</b> .....	<b>23</b>
<b>4.1 Program 1 – Unwrapped Instruments (1 – Instruments)</b> .....	<b>23</b>
<b>4.2 Program 2 (2- Instruments)</b> .....	<b>24</b>
<b>4.3 Program 3 (3 –Waste)</b> .....	<b>25</b>
<b>4.4 Program 4 (4 – Liquids)</b> .....	<b>26</b>
<b>4.5 Program 5 (5- Liquids)</b> .....	<b>27</b>
<b>4.6 Program 6 (6 – liq+Cool)</b> .....	<b>28</b>
<b>5 KEYBOARD (keys and display)</b> .....	<b>29</b>
<b>5.1 Description and Functions of the Front Panel Keyboard</b> .....	<b>30</b>
<b>5.2 Description of the Display</b> .....	<b>33</b>
<b>5.3 Description of Displayed Messages and Safety Measures</b> .....	<b>35</b>
<b>6 PRINTER</b> .....	<b>37</b>
<b>6.1 Printer Operation</b> .....	<b>37</b>
<b>6.2 DPU-20 Printer Handling</b> .....	<b>39</b>
<b>6.3 DPU 30 Printer Handling</b> .....	<b>40</b>

**TABLE OF CONTENT (Cont.)**

<b>PARAGRAPH</b>	<b>PAGE NO.</b>
<b>7</b>	<b><i>PREPARATION BEFORE STERILIZATION</i> ..... 41</b>
	<b><i>7.1 Filling the Water Reservoir</i>..... 44</b>
<b>8</b>	<b><i>OPERATING INSTRUCTIONS</i>..... 45</b>
	<b><i>8.1 Operation</i>..... 45</b>
	<b><i>8.2 Loading and unloading the Device</i> ..... 46</b>
<b>9</b>	<b><i>MAINTENANCE INSTRUCTIONS</i> ..... 48</b>
	<b><i>9.1 Preventive and Scheduled Maintenance</i> ..... 48</b>
	<b><i>9.2 Draining the Reservoir</i> ..... 49</b>
	<b><i>9.3 Cleaning water strainer</i> ..... 50</b>
	<b><i>9.4 Checking the Safety Valve</i>..... 51</b>
	<b><i>9.5 Replacing the Door Gasket</i> ..... 53</b>
	<b><i>9.6 Door Safety System for models 2540, 3150, 3850, 3870</i> ..... 54</b>
	<b><i>9.7 Door Safety System for models 5050, 5075</i>..... 55</b>
	<b><i>9.8 Cleaning Table Top Autoclaves with Chamber Brite™</i>..... 58</b>
<b>10</b>	<b><i>TROUBLESHOOTING</i>..... 60</b>
<b>11</b>	<b><i>SPARE PARTS LIST</i>..... 66</b>
<b>12</b>	<b><i>ACCESSORIES LIST</i> ..... 66</b>

**TABLE OF CONTENT (Cont.)**

<b>DRAWINGS</b>	<b>PAGE NO.</b>
<i>Front View</i> .....	<i>19</i>
<i>Rear View Model 2540</i> .....	<i>20</i>
<i>Rear View Models 3150, 3850, 3870</i> .....	<i>21</i>
<i>Rear View Models 5050, 5075</i> .....	<i>22</i>
<i>Front Panel Keyboard</i> .....	<i>29</i>
<i>Pouch Rack</i> .....	<i>62</i>
<i>Tray - Standard</i> .....	<i>63</i>
<i>Tray, Special ELC Version</i> .....	<i>64</i>
<i>Tray Holder, Special ELC Version</i> .....	<i>64</i>
<i>Baskets and Containers</i> .....	<i>65</i>

## 1 GENERAL



**Read the Operating Instructions carefully, before beginning any operation on the autoclave!**

### 1.1 Incoming Inspection

The autoclave should be unpacked and inspected for mechanical damage upon receipt. Observe packing method and retain packing materials until the unit has been inspected. Mechanical inspection involves checking for signs of physical damage such as: scratched panel surfaces, broken knobs, etc.

If damage is apparent, contact your dealer or point of purchase, so that they may notify the manufacturer and file a claim with the appropriate carrier.

All **Tuttnauer** products are carefully inspected prior to shipment and all reasonable precautions are taken in preparing them for shipment to assure safe arrival at their destination.

### 1.2 Warranty

We certify that this instrument is guaranteed to be free from defects in material and workmanship for one year against faulty components and assembly with the exception of glassware, lamps and heaters.

**The warranty does not include and does not replace routine treatment and preventive maintenance to be performed according to instructions in paragraph 9.1 (Preventive and Scheduled Maintenance).**

Our obligation is limited to replacing the instrument or parts, after our examination, if within one year after the date of shipment they prove to be defective. This warranty does not apply to any instrument that has been subjected to misuse, neglect, accident or improper installation or application, nor shall it extend to autoclaves that have been repaired or altered outside the factory without prior authorization from us.

**The Autoclave should not be used in a manner not described in this manual!**

### 1.3 Warranty Statement

The warranty registration must be completed and returned to our service departments; within fourteen (14) days of purchase or the warranty will be void.

Our Technical Service Depts can be reached at:

☒ **Tuttnauer Europe** b.v., Hoeksteen 11, 4815 PR, Breda, P.O. Box 7191, 4800 GD Breda, Netherlands. ☎+31/76-5423510, ☐Fax: +31/76-5423540, E-mail: [info@tuttnauer.nl](mailto:info@tuttnauer.nl)

Rudolf Gunz & Co. PTY LTD:

☒ Service Department, 26-34 Dunning Avenue, Ros, 2018, Sydney, Australia.

☒ Service Department, Locked bag 690, Beaconsfield, NSW 2014, Australia.

☎ +61-2-99356600 ☐Fax: +61-2-99356650

**Note:**

If there is any difficulty with this instrument, and the solution is not covered in this manual, contact our representative or us first. Do not attempt to service this instrument yourself. Describe the difficulty as clearly as possible so we may be able to diagnose the problem and provide a prompt solution.

If the autoclave is equipped with a printer, send along a copy of the last printout for our inspection. If replacement parts are needed, stipulate the model and serial number of the machine.

No autoclaves will be accepted for repair without proper authorization from us. All transportation charges must be paid both ways by the owner. This warranty will be void if the unit is not purchased from an authorized full service **Tuttnauer** dealer.

## **2 SAFETY INSTRUCTIONS**

The autoclave has unique characteristics. Please read and understand the operation instructions before first operation of the autoclave. The following issues may require instructions guidance provided by the manufacturer: how to operate the autoclave, the door safety mechanism, the dangers involved in circumventing safety means, how to ensure that the door is closed, and how to select a correct sterilization program.

Make sure that you know where the main power switch is, where the water cut-off valve is and where the steam and compressed air disconnection valves are located.

Autoclave maintenance is crucial for the correct and efficient function of the device. We enclose a log booklet that includes maintenance recommendations, with every device.

The weekly spore test is part of the preventive maintenance plan, along with the annual validation of the sterilization processes that ensures appropriate temperature dispersion within the chamber.

Never use the autoclave to sterilize corrosive products, such as: acids, bases and phenols, volatile compounds or solutions such ethanol, methanol or chloroform nor radioactive substances.

1. Never start using a new autoclave or a new steam generator, before the safety, licensing and authorization department has approved it for use.
2. All autoclave users must receive training in proper usage from an experienced employee. Every new employee must undergo a training period under an experienced employee.
3. A written procedure must be established for autoclave operation, including: daily safety tests, seal inspection and door hinge inspection, smooth action of the closing mechanism, chamber cleaning, prevention of clogging and preservation from corrosion, what is permitted and what is prohibited for sterilization and choosing a sterilization program.
4. Liquids may be sterilized only with the "liquids" program. The container must be covered but not sealed. Sealed bottles may only be sterilized using a special program. The bottle must be either Pyrex or a Borosilicate glass bottle.
5. When sterilizing plastic materials, make sure that the item can withstand sterilization temperature. Plastic that melts in the chamber is liable to cause a great deal of damage.
6. Individual glass bottles may be placed within an appropriate container that will be placed on a tray. Never place glass bottles on the floor of the autoclave. Never fill more than 2/3 of the bottle volume.
7. On closing the autoclave's door, make sure it is properly locked before activating.
8. Before withdrawing trays, wear heat resistant gloves.
9. Before opening the door, verify that there is no pressure in the chamber (chamber pressure gauge is located on the autoclave's front panel).
10. Open the door slowly to allow steam to escape and wait 5 minutes before you remove the load. When sterilizing liquids, wait 10 minutes.
11. Once a month, ensure that the safety valves are functioning, and once annually a certified tester must conduct pressure chamber safety tests.



12. Once annually, or more frequently, effective tests must be performed, i.e., calibration and validation.
13. Examine the condition of assemblies on a regular basis. Make sure there are no leaks, breaks, blockages, whistles or strange noises.
14. It is required to conduct maintenance operations as instructed.
15. Immediately notify the person in charge of any deviation or risk for the proper function of the device.

### 3 GENERAL INFORMATION

#### 3.1 Introduction

Models 2540, 3150, 3850, 3870, 5050 and 5075 EL are table-top sterilizers designed especially for the sterilization of instruments, liquids, and other materials in hospital laboratories, medical laboratories, research institutes, food laboratories and pharmaceutical facilities.

A computerized control unit ensuring a fully automatic sterilization cycle controls the autoclave.

The temperature and pressure are controlled through sensors placed inside and outside the media container or bottles.

A special feature of the EL series is the option of a fast cooling stage for liquids. In this stage pressure in the chamber is increased by means of compressed air to compensate the fast decreasing of pressure due to the fast cooling. The fast cooling shortens the time required for safe handling of bottles.

Five automatic sterilization programs are available, according to the material to be sterilized, as well as one special program (No. 5 – 105°C). The sixth program is an optional program containing a cooling stage.

The sterilizer has multiple built - in safety devices, which provides adequate protection to ensure the safety of operating personnel.

On all models, a printer is an optional addition to the autoclave. The printer prints the preset and actual parameters of the cycle (temperature, time and pressure/vacuum).

The autoclave is provided with a pressure gauge that is used as guide only. Should there be a power failure during the operation of the autoclave, the pressure gauge indicates to the operator that there is pressure in the chamber.

A deviation of +1.6% is accepted.

#### **NOTE:**

After operating the sterilizer, brown stains might appear on the bottom of the chamber. These stains are a result of the heating elements that are located at the lower external part of the chamber. The brown color is a common phenomenon, can easily be removed, and will not have any effect on the sterilized goods.

This manual is intended to give the user a general understanding of how the autoclave works and indicates the best ways to operate and take care of it in order to obtain optimum results and a trouble-free operation. After reading this manual, operating the autoclave should be straightforward. However, since the autoclave is built using high technology sensitive components, no attempt should be made by the user or any other unauthorized person to repair or recalibrate it.

**Only technical personnel having proper qualifications, holding technical documentation and adequate test instrumentation are authorized to undertake repair or service.**



#### 3.2 *Stand – by heating mode*

The autoclave provides an option of heating the chamber in stand-by mode between cycles with a very low power in order to reduce total cycle time (1.6% of the total power only). The autoclave turns off automatically if the interval between the sterilization cycles is more than 2 hours.

### 3.3 *Operating Conditions*

This device is for indoor use only!

The sterilizer should be loaded only with autoclavable material!

The environment shall not exceed an ambient temperature of 40°C and a relative humidity of 85% respectively.



#### **Caution!**

**Waste water should be brought into the public net in accordance with the local rules or requirements i.e ONLY NON-HAZARDOUS LIQUIDS SHALL BE DISPOSED IN PUBLIC SEWAGE!**

### 3.4 *Utilities*

<b>Electric Power Supply</b>		
<b>Model</b>	<b>Power Supply</b>	<b>Recommended circuit breaker</b>
<b>2540, 3150</b>	1Ph, 230V/50Hz	20A
<b>3850</b>	1 Ph, 230V/50Hz	25A
<b>3870 with switching box</b>	1 Ph, 220-240V/50Hz	25A
<b>3850/70, 5050/75</b>	3 Ph, 400V/50Hz	20A
<b>5050/75</b>	3 Ph, 230V/50Hz	20A
<b>5050/75 with switching box</b>	1 Ph, 230V/50Hz	40A

<b>Compressed Air (ELC models only)</b>	1/2" 2-5 Bar
<b>Tap water (ELC models only)</b>	1/2", 2-5 Bar
<b>Drain (ELC models only)</b>	Withstanding temp. of 80°C



#### **Attention:**

The electrical net must be protected with a current leakage safety relay.

The electrical network must comply with local rules or regulations.

### 3.5 *Load on counter*

The counter (or shelf, etc.) on which the autoclave shall be placed must be able to withstand, at least, the following weight:

<b>Model</b>	2540	3150	3850	3870	5050	5075
<b>Weight</b>	65 kg	95 kg	115 kg	140 kg	285 kg	310 kg

### 3.6 *Construction*

The main parts of the autoclave are made of materials as indicated below:

- ◆ Chamber and door are made of stainless steel
- ◆ Trays are made of stainless steel.
- ◆ Water reservoirs of models 2540, 3150, 3850, 3870 are made of hard plastic material.
- ◆ Water reservoirs of models 5050, 5075 are made of stainless steel.
- ◆ Door handle is made of hard plastic material, which is safe to touch and thermo-insulated.

### 3.7 *Environment Emission Information*

1. The peak sound level generated by the autoclave is less than 70 dBA with background noise of 60 dBA.
2. The total heat per hour transmitted by the autoclave is < 100 W/h for all models.

### 3.8 *Directives and Standards*

Every autoclave meets the provisions of the following Directives and is constructed in compliance with the following Standards:

#### 3.8.1 *Technical Directives*

1. Pressure Equipment Directive 97/23/EC.
2. Council Directive for low voltage equipment 73/23/EEC.
3. Electromagnetic Compatibility Requirements Directive 89/336/EC.

#### 3.8.2 *Technical Standards*

1. ASME code (models 2540, 3150, 3850, 3870, 5050, 5075).
2. EN 13445 (models 5050, 5075).
3. IEC-61010-1 & IEC-61010-2-041 - Safety requirements for medical device.
4. EN 61326 – EMC Requirements .

#### 3.8.3 *Quality standards*

The manufacturing plant meets the following quality standards:

1. EN ISO 9001:2008– Quality System
2. ISO 13485:2003 – Quality systems – Medical devices.

### 3.9 *Electrical Data*

<b>Model</b>	<b>Power consumption</b>	<b>Supply Voltage</b>	<b>Line current</b>	<b>Protection against electrical shock</b>
<b>2540</b>	4 x 550W	1Ph, 230V/50Hz	9.6A	Class I (IEC 60601-1)
<b>3150</b>	4 x 600W	1Ph, 230V/50Hz	10.4A	
<b>3850</b>	4 x 800W	3Ph, 400V/50Hz	7.0A	
	4 x 800W	1Ph, 230V/50Hz	13.9A	
<b>3870</b>	6 x 800W	3 Ph, 400V/50Hz	7.0A	
<b>5050</b>	4 x 1100W	3 Ph, 400V/50Hz	9.6A	
	4 x 1100W	3 Ph, 230V/50Hz	12.0A	
<b>5075</b>	6 x 1100W	3 Ph, 400V/50Hz	9.6A	

### 3.10 Overall Dimensions Model 2540 EL

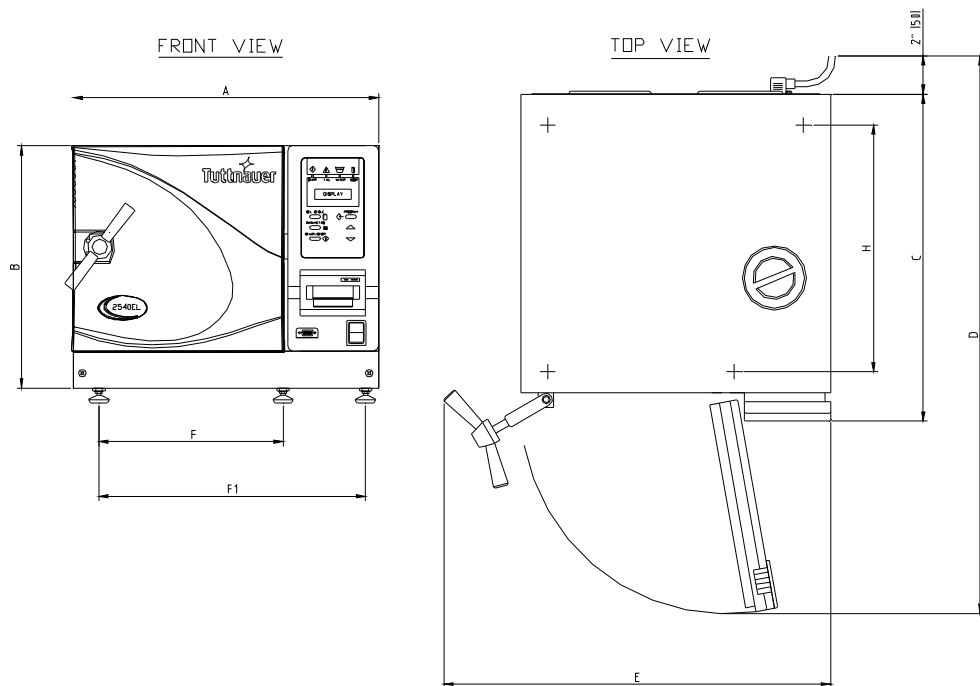

		mm	in
Overall Dimensions	A	510	14.4
	B	365	20.0
	C	545	21.5
Maximum dimensions (door open)	D	910	35.8
	E	655	25.8
Distance between supporting legs F1 – front legs F - rear legs	F	415	16.4
	F1	422	16.6
	G	50	2.0
	H	400	15.8
Chamber	diameter	250	9.8
	Depth	420	16.5
Reservoir volume		3.0 lit.	0.8 gal
Minimum water volume in Reservoir		0.8 lit.	0.21 gal
Max. Allowable Working Pressure (MAWP)		2.76 bar (40 psi)	
Load No. counter		Counting from 0 to 3000 and nullifies.	

### 3.11 Overall Dimensions Models 3150 EL

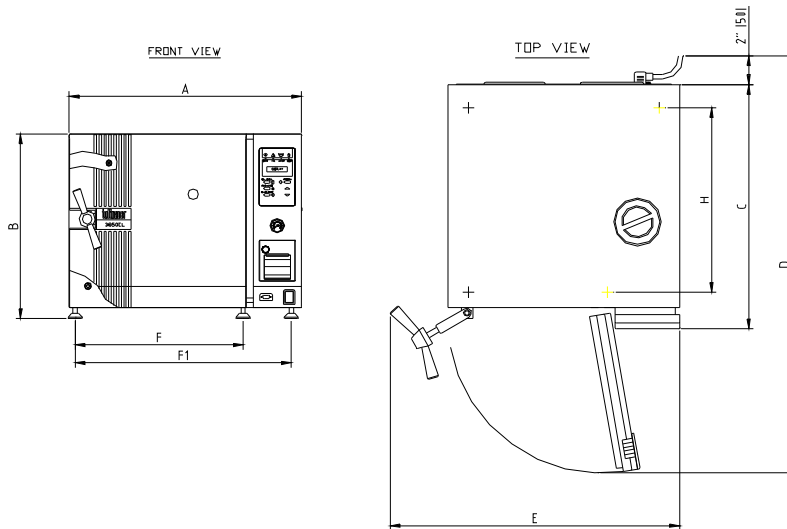

		mm	in
Overall Dimensions	A	600	23.6
	B	450	17.7
	C	695	27.4
Maximum dimensions (door open)	D	1120	44.1
	E	730	28.7
Distance between supporting legs F1 – front legs F - rear legs	F	370	14.6
	F1	490	19.3
	G	50	2.0
	H	515	20.3
Chamber	diameter	310	12.2
	Depth	500	19.7
Reservoir volume		6.0 lit.	1.6 gal
Minimum water volume in Reservoir		2.0 lit.	0.53 gal
Max. Allowable Working Pressure (MAWP)		2.76 bar (40 psi)	
Load No. counter		Counting from 0 to 3000 and nullifies	

### 3.12 Overall Dimensions Models 3850, 3870 EL

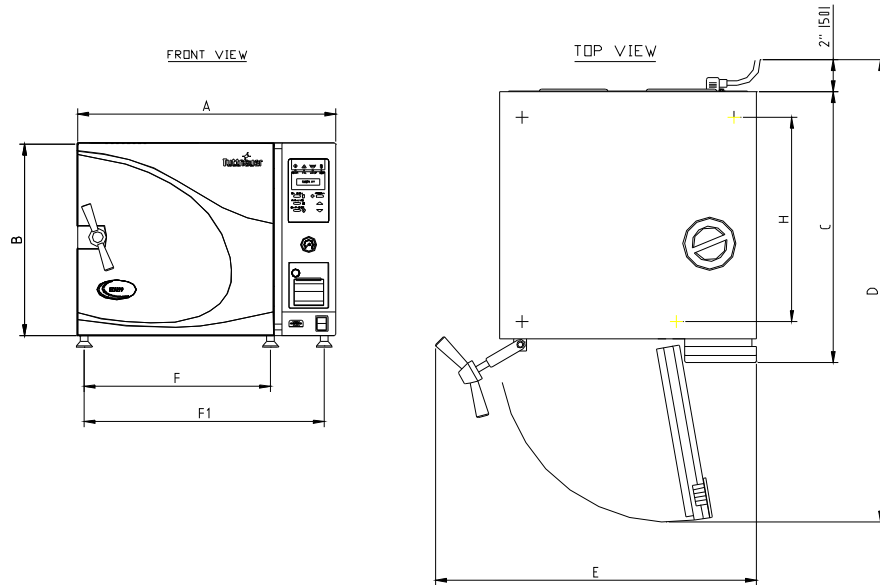

Model		3850		3870	
		mm	in	mm	in
Overall Dimensions	A	660	26.0	660	26.0
	B	525	20.7	525	20.7
	C	695	27.5	875	34.5
Maximum dimensions (door open)	D	1155	45.5	1335	53.0
	E	815	32.0	815	32.0
Distance between supporting legs F1 – front legs F - rear legs	F	450	17.7	450	17.7
	F1	564	22.2	564	22.2
	G	50	2.0	50	2.0
	H	555	21.8	725	30.5
Chamber	diameter	384	15.1	384	15.1
	Depth	581	20.1	690	27.2
Reservoir volume		6.0 lit.	1.6 gal	6.0 lit.	1.6 gal
Minimum water volume in Reservoir		2.0 lit.	0.53 gal	2.0 lit.	0.53 gal
Max. Allowable Working Pressure (MAWP)		2.76 bar (40 psi)			
Load No. counter		Counting from 0 to 3000 and nullifies.			

### 3.13 Overall Dimensions Models 5050, 5075 EL

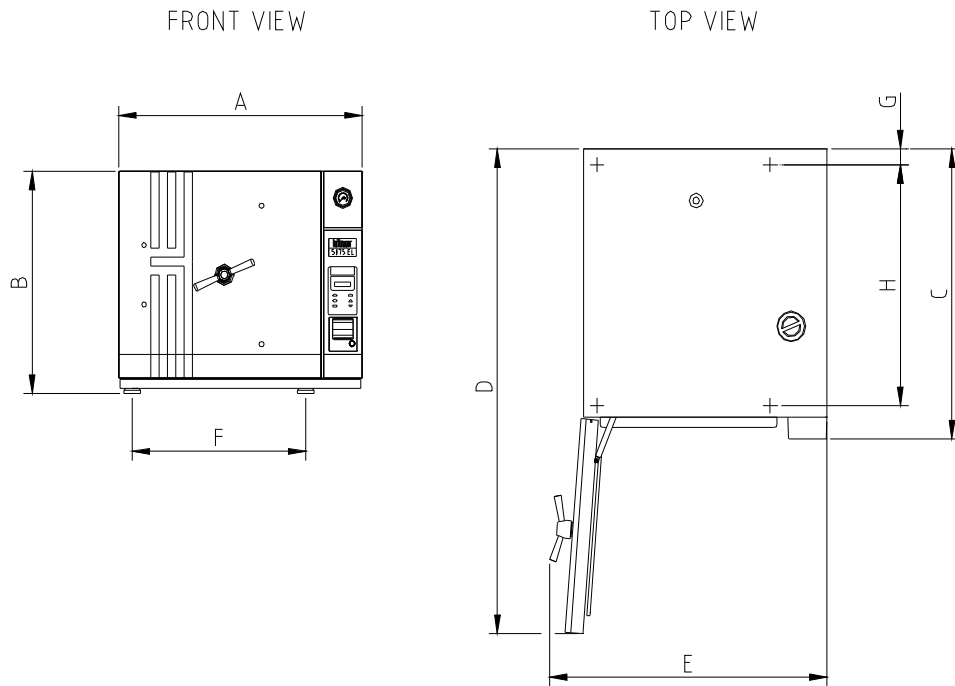

Model		5050		5075	
		mm	in	mm	in
Overall Dimensions	A	880	34.6	880	34.6
	B	730	28.7	730	28.7
	C	815	32.1	1045	41.1
Maximum dimensions (door open)	D	1440	56.7	1640	64.6
	E	803	31.6	803	31.6
Distance between supporting legs	F	626	24.7	626	24.7
	G	54	2.1	54	2.1
	H	594	23.4	824	32.4
Chamber	diameter	500	19.7	500	19.7
	Depth	500	19.7	750	29.5
Reservoir volume		20 lit.	4.4 gal	20 lit.	4.4 gal
Minimum water volume in Reservoir		10 lit.	2.2 gal	10 lit.	2.2 gal
Max. Allowable Working Pressure (MAWP)		2.76 bar (40 psi)			
Load No. counter		Counting from 0 to 3000 and nullifies.			



### 3.14 Loading Capacities

#### 3.14.1 Erlenmeyer Flasks

Type	2540	3150	3850	3870	5050	5075
250 ml	4	10	12	16	20	31
500 ml	3	5	8	11	12	19
1000 ml	—	3	4	5	8	12
2000 ml	—	—	3	4	4	7
3000 ml	—	—	2	3	3	5
5000 ml	—	—	—	—	2	3

#### 3.14.2 Medium Flasks (Schott)

Type	2540	3150	3850	3870	5050	5075
250 ml.	6	14	20	27	33	48
500 ml	4	10	11	16	18	28
1000 ml	3	6	9	12	14	21
2000 ml	—	3	4	5	7	10
5000 ml	—	—	2	3	3	5

### 3.15 Symbol Description



**Caution! Consult accompanying documents**



**Caution! Hot surface.**



**Caution! Hot steam.**



**Protective earth (Ground)**

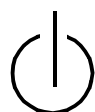

**On-Off**

3.16 Technical Specifications EL

Models	Chamber dimensions DIA x D	Volume of chamber	Volume of mineral free water reservoir	Tray dimensions W X D	No. of trays	Printer	Autoclave's Weight	Shipping Weight	Shipping Volume
<b>2540</b>	25.4 x 47.5cm (10 " x 18.7")	23 liters. (6 US gal.)	3.0 liters. (0.66 US gal)	11.4 x 38.5 cm (4.5" x 15.2 ")	1	Yes	44 kg. (97 lbs.)	48 kg. (106 lbs.)	0.27m <sup>3</sup> (9.4 cu. f.)
<b>3150</b>	31.0 x 58.0cm (12.2" x 23.0")	42.5 liters (11.2 US gal)	3.0 liters. (0.66 US gal)	17.2 x 51.6 cm (6.8" x 20.3")	1	Yes	62 kg. (136.7 lbs.)	81 kg. (178 lbs.)	0.63 m <sup>3</sup> (22.2cu.f.)
<b>3850</b>	38.0 x 58.0 cm. (15.0" x 23.0")	65 liters (17.17 US gal)	7.5 liters. (2.0 US gal)	19.5 x 51.0 cm (7.7" x 20.1 ")	1	Yes	70 kg. (154.3 lbs.)	89 kg. (196 lbs.)	0.63 m <sup>3</sup> (22.2cu.f.)
<b>3870</b>	38.0x76.0 cm (15.0" x 30")	85 liters (22.5 US gal)	7.5 liters. (2.0 US gal)	19.5 x 69.0 cm (7.7" x 27.2" )	1	Yes	86 kg. (190 lbs.)	106 kg. (234 lbs.)	0.76m <sup>3</sup> (26.8cu.f)
<b>5050</b>	50.0 x 61.0 cm (19.7" x 24")	110 liters (29.1 US gal)	18.5 liters. (4.9 US gal)	32.0 x 55.0 cm (12.6" x 21.7")	1	Yes	188 kg (414 lbs.)	265 kg (584 lbs.)	1.7 m <sup>3</sup> (60 cu.f)
<b>5075</b>	50.0 x 84.0 cm (19.7" x 33.1")	160 liters (42.3 US gal)	18.5 liters. (4.9 US gal)	32.0 x 78.0 cm (12.6" x 30.7")	1	Yes	199 kg (439 lbs.)	275 kg (606 lbs.)	1.7 m <sup>3</sup> (60 cu.f)

### 3.17 Water quality

#### 3.17.1 Water for generating steam

The distilled or mineral – free water supplied to the autoclave should have the physical characteristics and maximum acceptable level of contaminants indicated in the table below:

**Physical Characteristics and Maximum acceptable contaminants levels in steam for sterilizers (According to EN 13060:2004).**

Element	Condensate – allowable content
Silicium oxide. SiO <sub>2</sub>	≤0.1 mg/kg
Iron	≤0.1 mg/kg
Cadmium	≤0.005 mg/kg
Lead	≤ 0.05 mg/kg
Rest of metals except iron, cadmium, lead	≤0.1 mg/kg
Chloride (Cl)	≤0.1 mg/kg
Phosphate (P <sub>2</sub> O <sub>5</sub> )	≤0.1 mg/kg
Conductivity (at 20°C)	≤3 µs/cm
pH value (degree of acidity)	5 to 7
Appearance	Colourless clean without sediment
Hardness (Σ Ions of alkaline earth)	≤0.02 mmol/l



**Compliance with the above data should be tested in accordance with acknowledged analytical methods, by an authorized laboratory.**

**Attention:**

**We recommend testing the water quality once a month. The use of water for autoclaves that do not comply with the table above may have severe impact on the working life of the sterilizer and can invalidate the manufacturer's guarantee.**

#### 3.17.2 Reverse Osmosis

A Reverse Osmosis (RO) system may be used to improve the quality of the water used to generate steam in the autoclave chamber.

In RO, the water is forced through a semi-penetrable membrane, which filters out contaminants to a high degree of efficiency. In deionisation (DI) ions and charged particles are removed either by electric fields or by ion exchange in resin beds.

Although the RO cannot normally attain the degree of purity possible with the DI methods, it is more than adequate for the feed water intended for clean-steam generators.

Moreover the RO has several advantages:

1. RO is cheaper to install and to run than DI.
2. RO removes particulate matter, organic molecules and pyrogens that DI cannot remove
3. RO water is less corrosive to steel and copper than DI water.
4. RO maintenance requirements are less demanding than those of the DI units.

Therefore the use of mineral free water will contribute to better performance and longer life of the autoclave.

## FRONT VIEW

No.	Description
1	Reservoir water drain valve
2	Ring for drain valve
3	Door closing device
4	Door switch
5	Autoclave cover
6	Water reservoir cover
7	Water reservoir – assembly
8	Safety valve
9	Air relief valve
10	Pressure gauge
11	Validation port (under door cover)
12	Main switch
13	Printer
14	Front panel key board
15	Completion to panel
16	Panel base
17	Flat cable for ANL-T1 – RS232
18	RS232 port cover
19	Pressure gauge panel

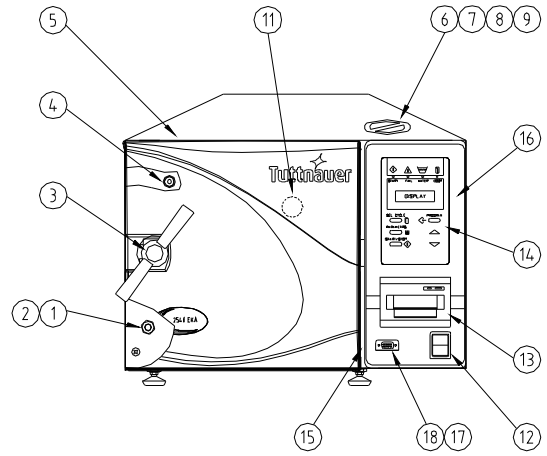

**Model 2540**

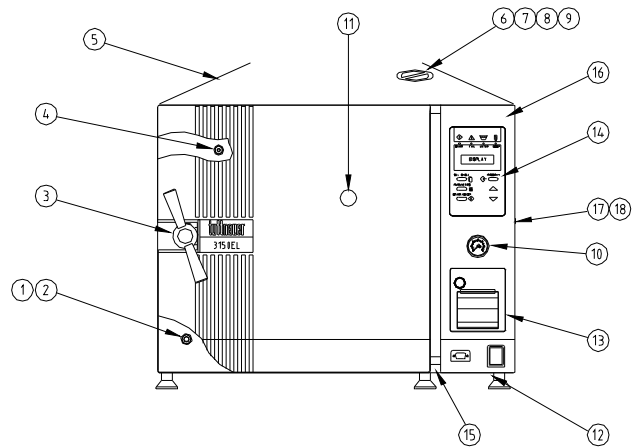

**Model 3150**

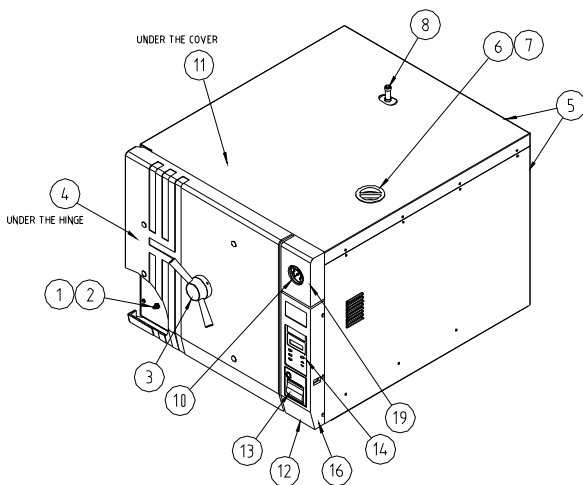

**Models 5050/5075**

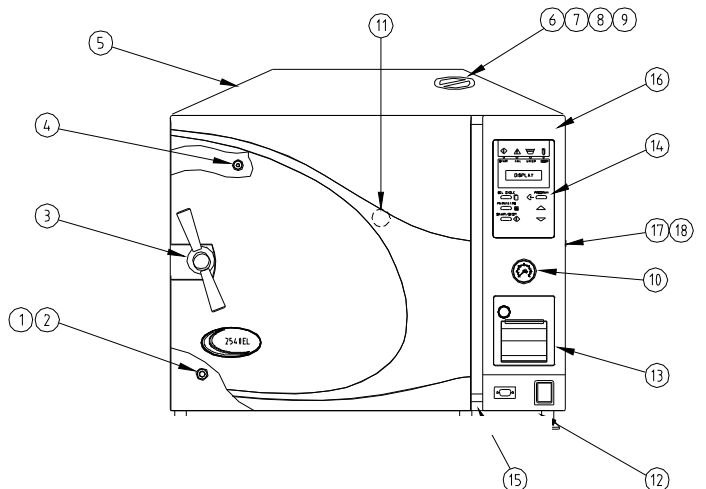

**Model 3850/3970**

**REAR VIEW MODEL 2540**

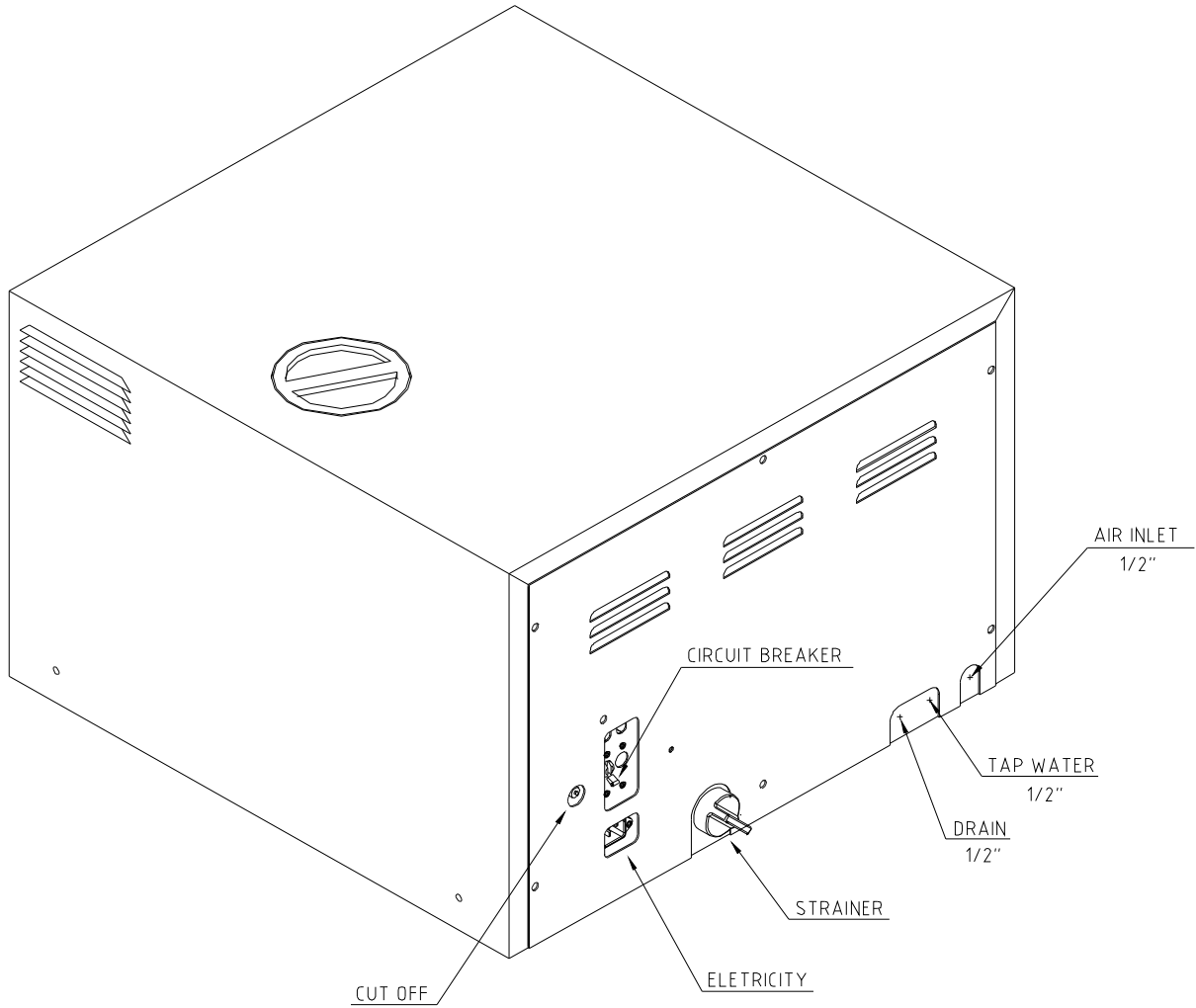

**REAR VIEW MODELS 3150, 3850, 3870**

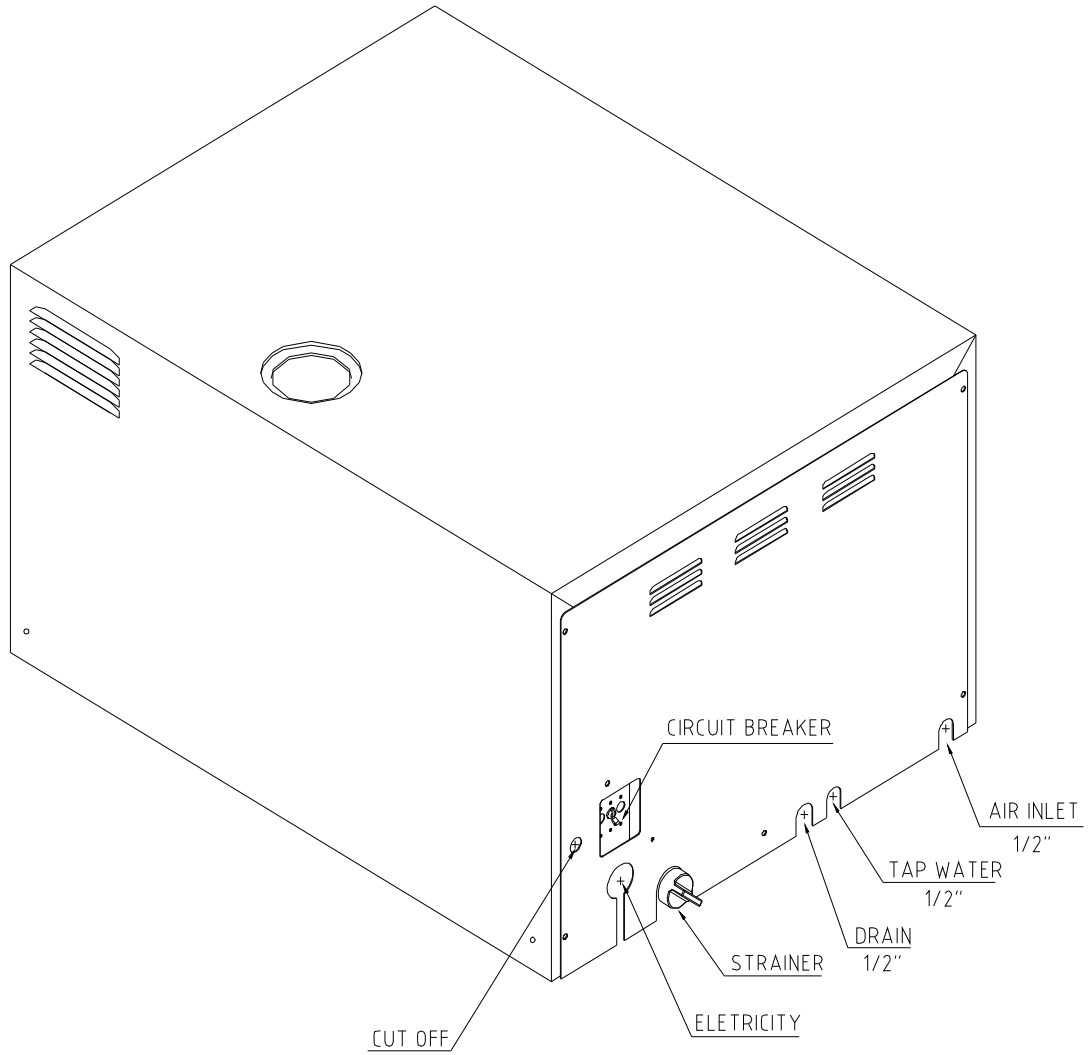

## REAR VIEW MODELS 5050, 5075

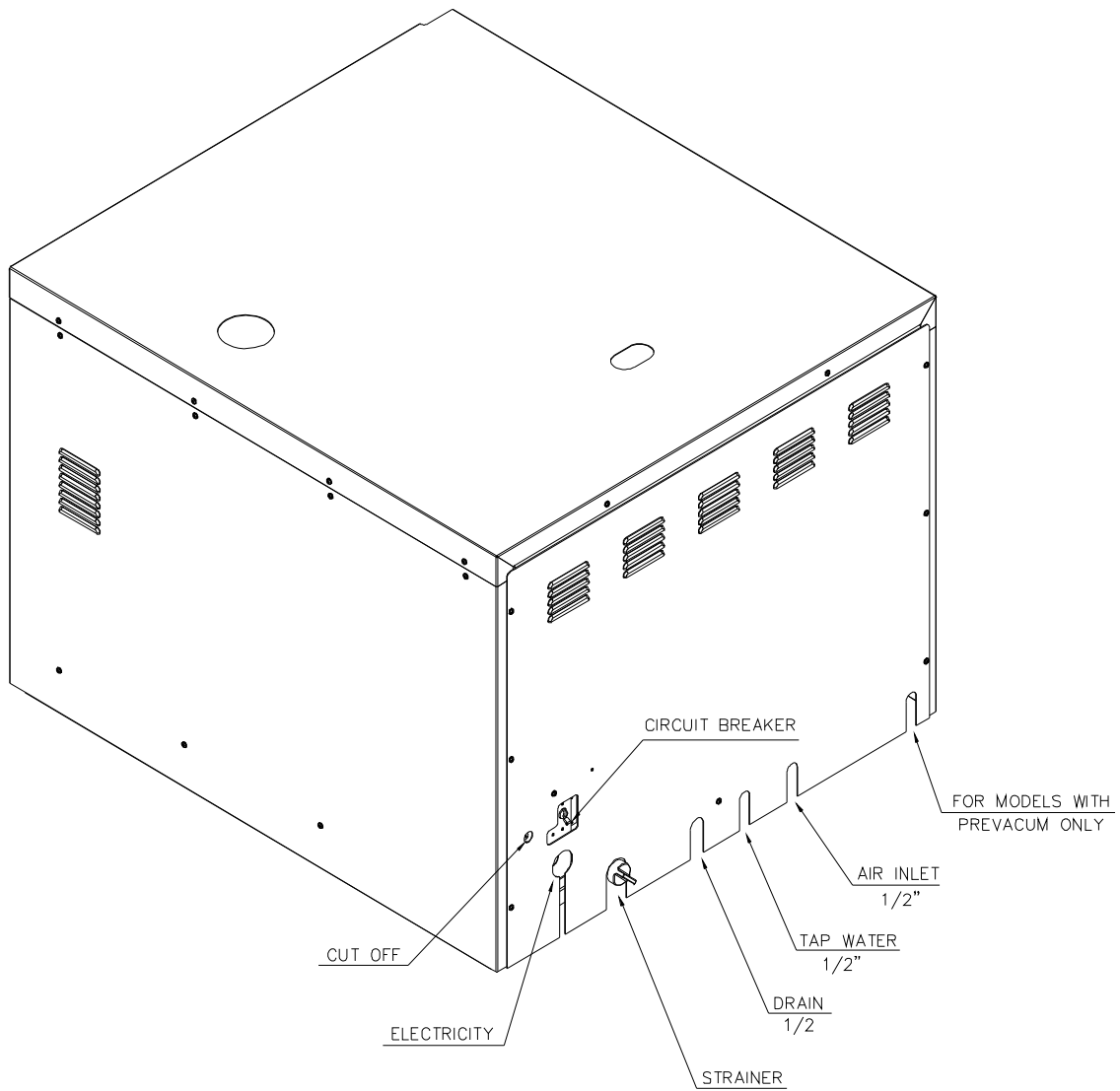



## 4 STERILIZATION PROGRAMS

The autoclave offers 6 sterilization programs, with or without drying stage.

### 4.1 Program 1 – Unwrapped Instruments (1 – Instruments)

Program 1 is recommended for sterilizing unwrapped instruments and materials for immediate use and preventing cross infection at temperature 134°C. No drying is required.

#### Nominal Parameters

- ◆ Sterilization temperature: 134°C (273°F).
- ◆ Sterilization time: 3 minutes.

#### Operations Sequence

- ◆ Heating phase; water enters the chamber and is heated until the sterilization temperature is reached.
- ◆ Sterilization phase; temperature is maintained constant at the preset value for the sterilization time.
- ◆ Fast exhaust phase (Ex. Mode=1); steam is rapidly exhausted from the chamber, until pressure equalizes to atmospheric pressure.



#### Note:

*The sterility of instruments processed in unwrapped cycles cannot be maintained if exposed to non-sterile environment.*

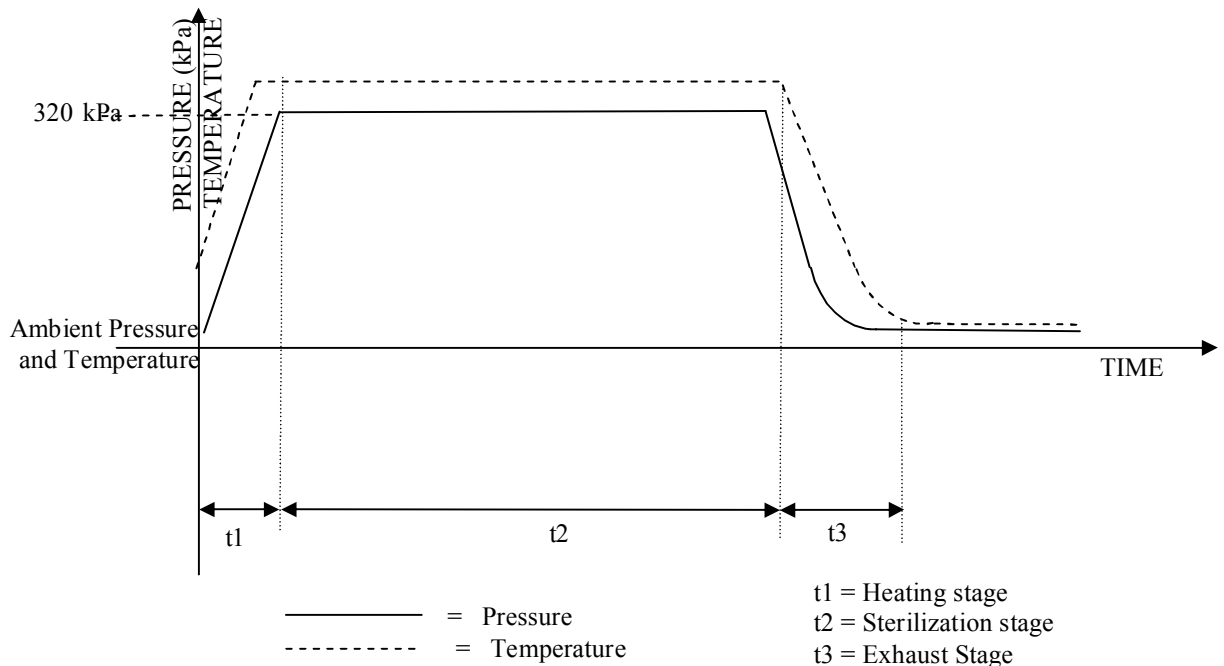

#### 4.2 Program 2 (2- Instruments)

For instruments and materials when the manufacturer recommends autoclaving at temperatures of up to 121°C with a drying cycle.

##### *Nominal parameters*

- ◆ Sterilization temperature: 121°C (250°F).
- ◆ Sterilization time: 15 minutes.
- ◆ Drying time: 15 minutes.

##### *Operations Sequence*

- ◆ Heating phase; water enters the chamber and warms up until the sterilization temperature is reached.
- ◆ Sterilization phase; temperature is maintained constant at the preset level for the sterilization time.
- ◆ Fast exhaust phase (Ex Mode=1); steam is rapidly exhausted from the chamber, until pressure equalizes to atmospheric pressure.
- ◆ Drying phase; Chamber is heated for 15 minutes at reduced power.

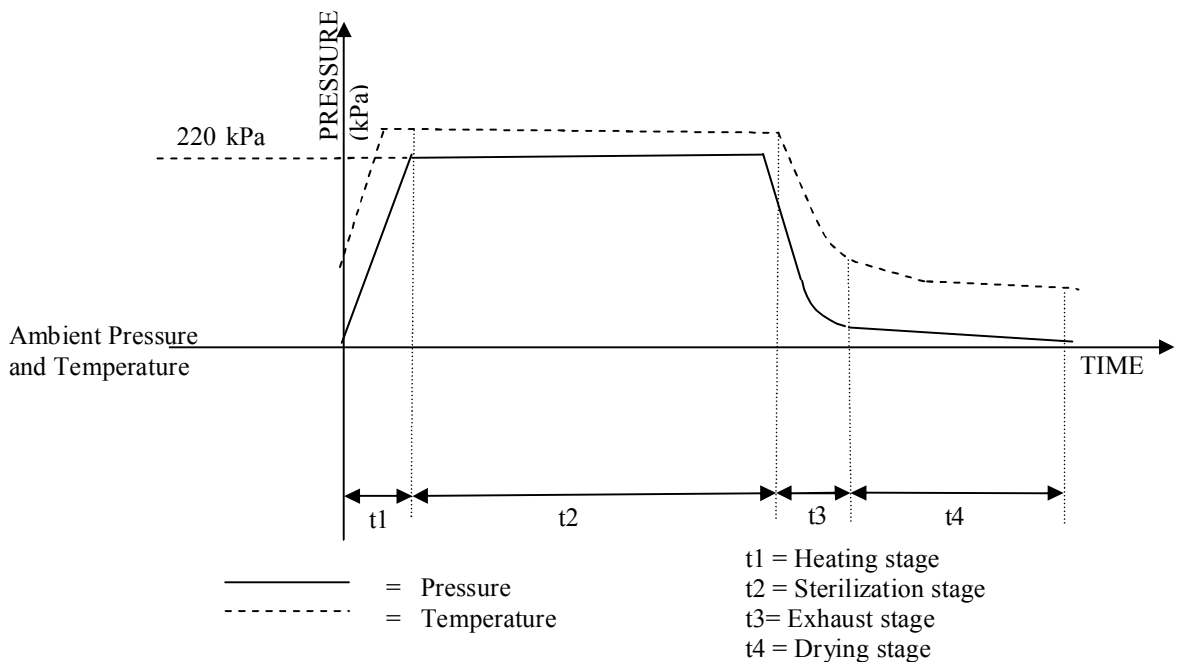

#### 4.3 Program 3 (3 – Waste)

For waste materials when the manufacturer recommends autoclaving at a temperature of 121°C with a drying cycle.

##### *Nominal Parameters*

- ◆ Sterilization temp.: 121°C (250°F).
- ◆ Sterilization time: 20 minutes.
- ◆ Dry time: 5 minutes.

##### *Operations Sequence*

- ◆ Heating phase; water enters the chamber and heats up until the sterilization temperature is reached.
- ◆ Sterilization phase; temperature is maintained constant at the preset level for the sterilization time.
- ◆ Slow exhaust (Ex. Mode =3); steam is slowly exhausted from the chamber, until it reaches a temperature of 85°C.
- ◆ Drying phase; Chamber is heated for 5 minutes at reduced power.

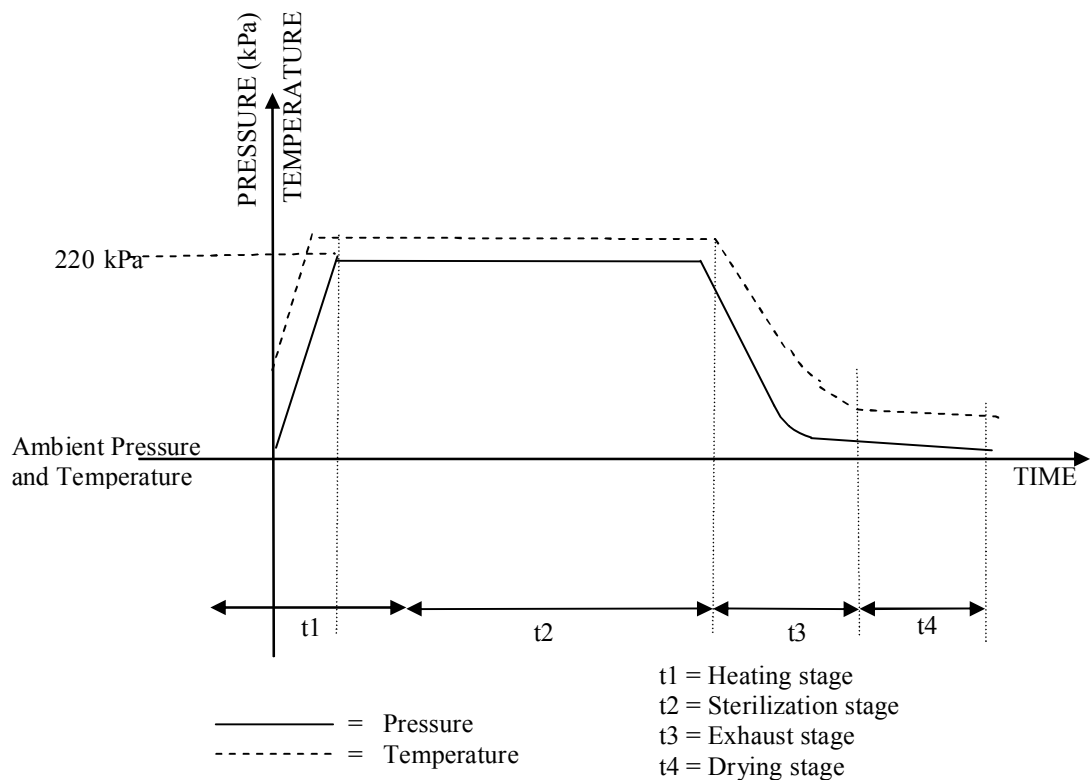

#### 4.4 Program 4 (4 – Liquids)

For liquids when the manufacturer recommends autoclaving at temperatures of 121°C with no drying cycle.

##### *Nominal Parameters*

- ◆ Sterilization temperature: 121°C(250°F).
- ◆ Sterilization time: 20 minutes.

##### *Operations Sequence*

- ◆ Heating phase; The water enters the chamber and heats up until the sterilization temperature is reached.
- ◆ Sterilization phase; temperature is maintained constant at preset level for the sterilization time.
- ◆ Slow exhaust phase (Ex. Mode=4); steam is slowly exhausted from the chamber, until it reaches the required temperature of around 85°C and the pressure equals the atmospheric pressure.

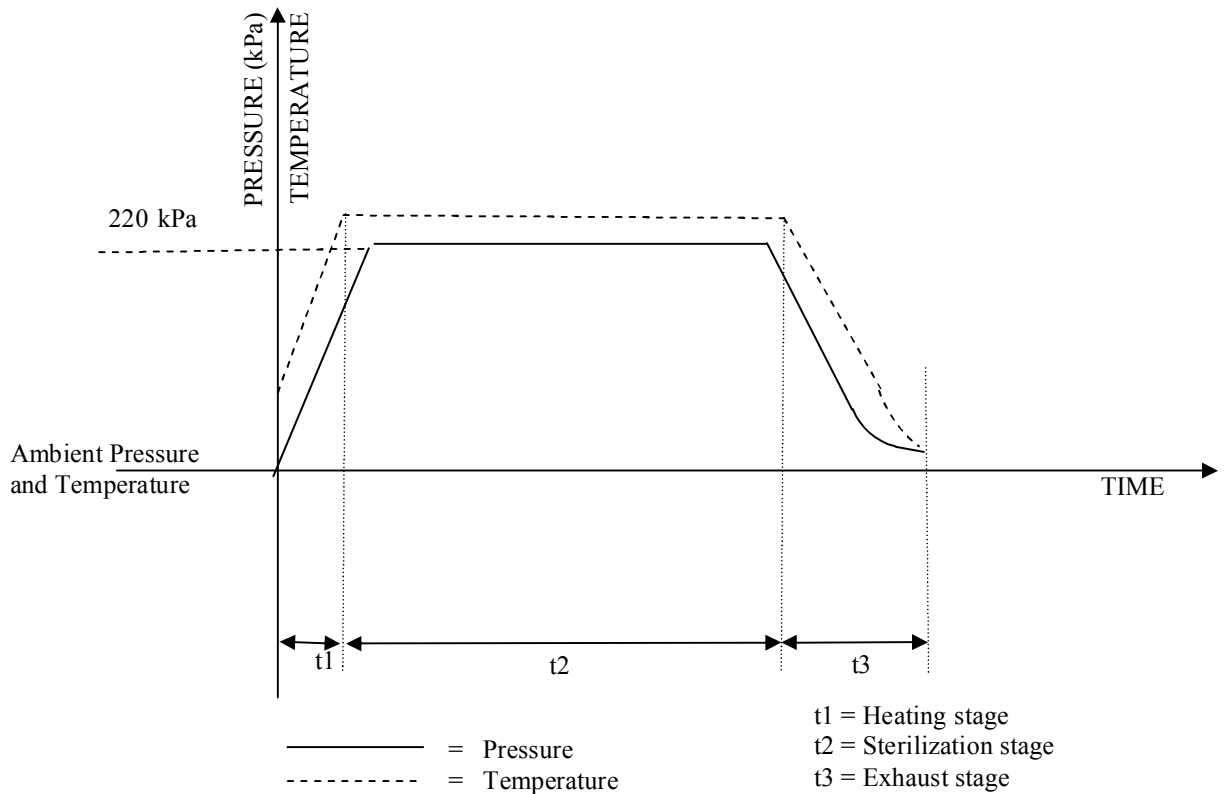

#### 4.5 Program 5 (5- Liquids)

For liquids when the manufacturer recommends processing at temperatures of 105°C with no drying cycle.

##### *Nominal Parameters*

- ◆ Temperature: 105°C
- ◆ Time: 18 minutes.

##### *Operations Sequence*

- ◆ Heating phase; The water enters the chamber and heats up until the sterilization temperature is reached.
- ◆ Sterilization phase; temperature is maintained constant at the preset level for the sterilization time.
- ◆ Slow exhaust phase (Ex. Mode = 4); steam is slowly exhausted from the chamber, until it reaches the required temperature of around 85°C and the pressure equals the atmospheric pressure.

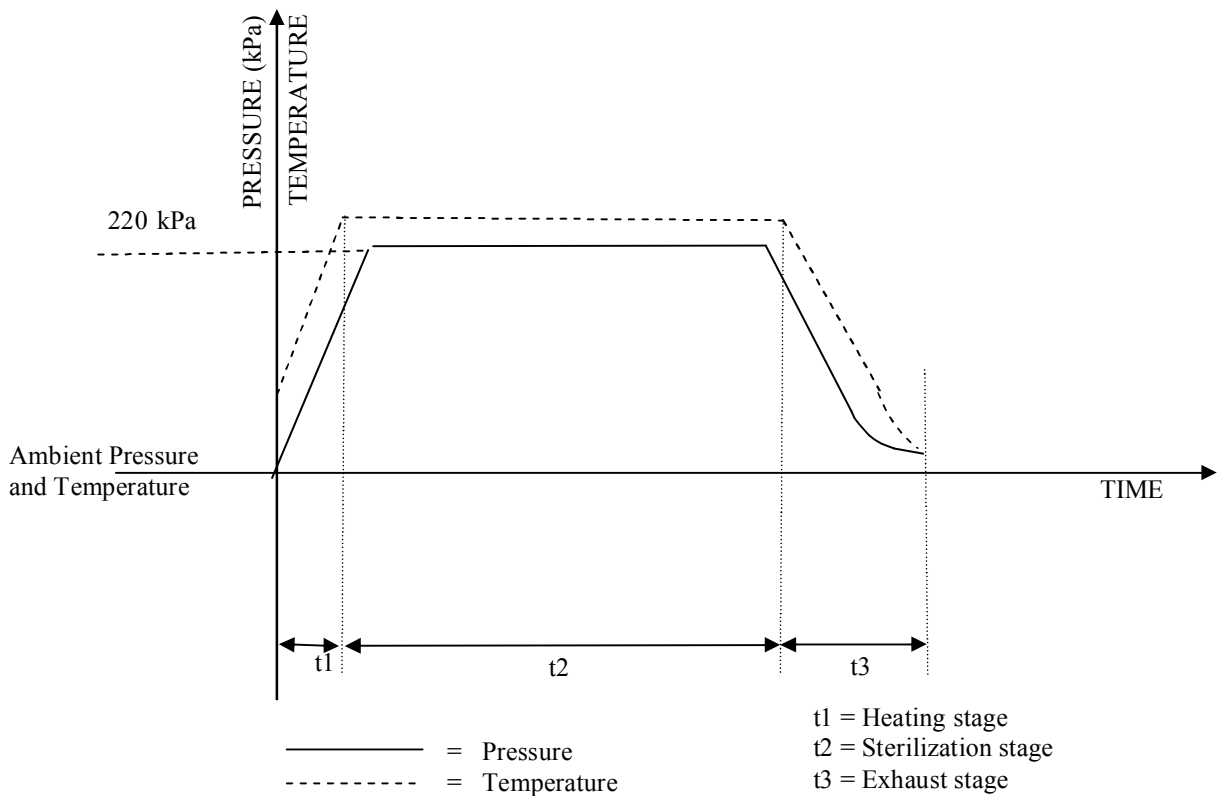

#### 4.6 Program 6 (6 – liq+Cool)

For materials when the manufacturer recommends processing at temperatures of 121°C and cooling to temperatures of 85°C with no drying cycle.

##### Nominal Parameters

- ◆ Sterilization temperature: 121°C
- ◆ Sterilization time: 30 minutes.

##### Operations Sequence

- ◆ Heating phase; The water enters the chamber and heats up until the sterilization temperature is reached.
- ◆ Sterilization phase; temperature is maintained constant at the preset level for the sterilization time.
- ◆ Forced cooling to 85°C, while the pressure in the chamber remains the same as the sterilization pressure, by supplying compressed air into the chamber. The forced cooling shortens the cooling stage significantly.
- ◆ Slow exhaust phase (Ex. Mode=5); until the pressure equals the atmospheric pressure.

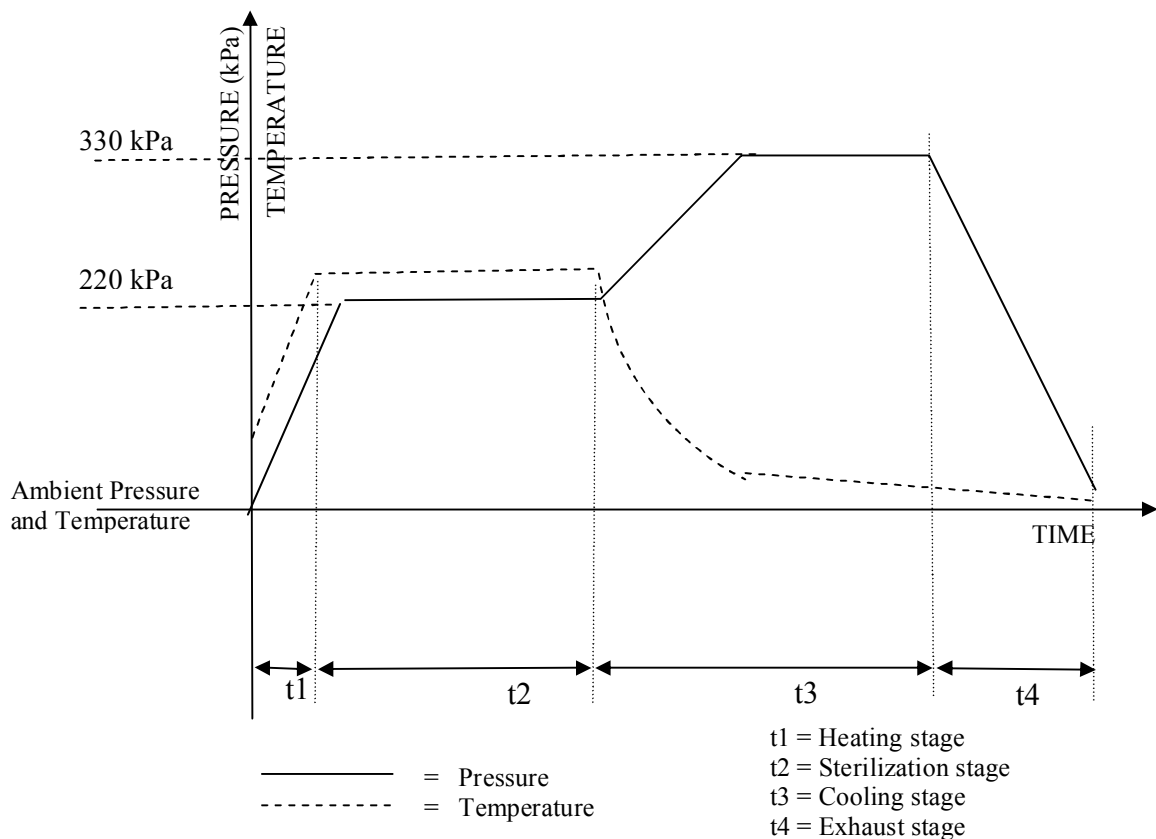

5 **KEYBOARD** (*keys and display*)

**Front Panel Keyboard**

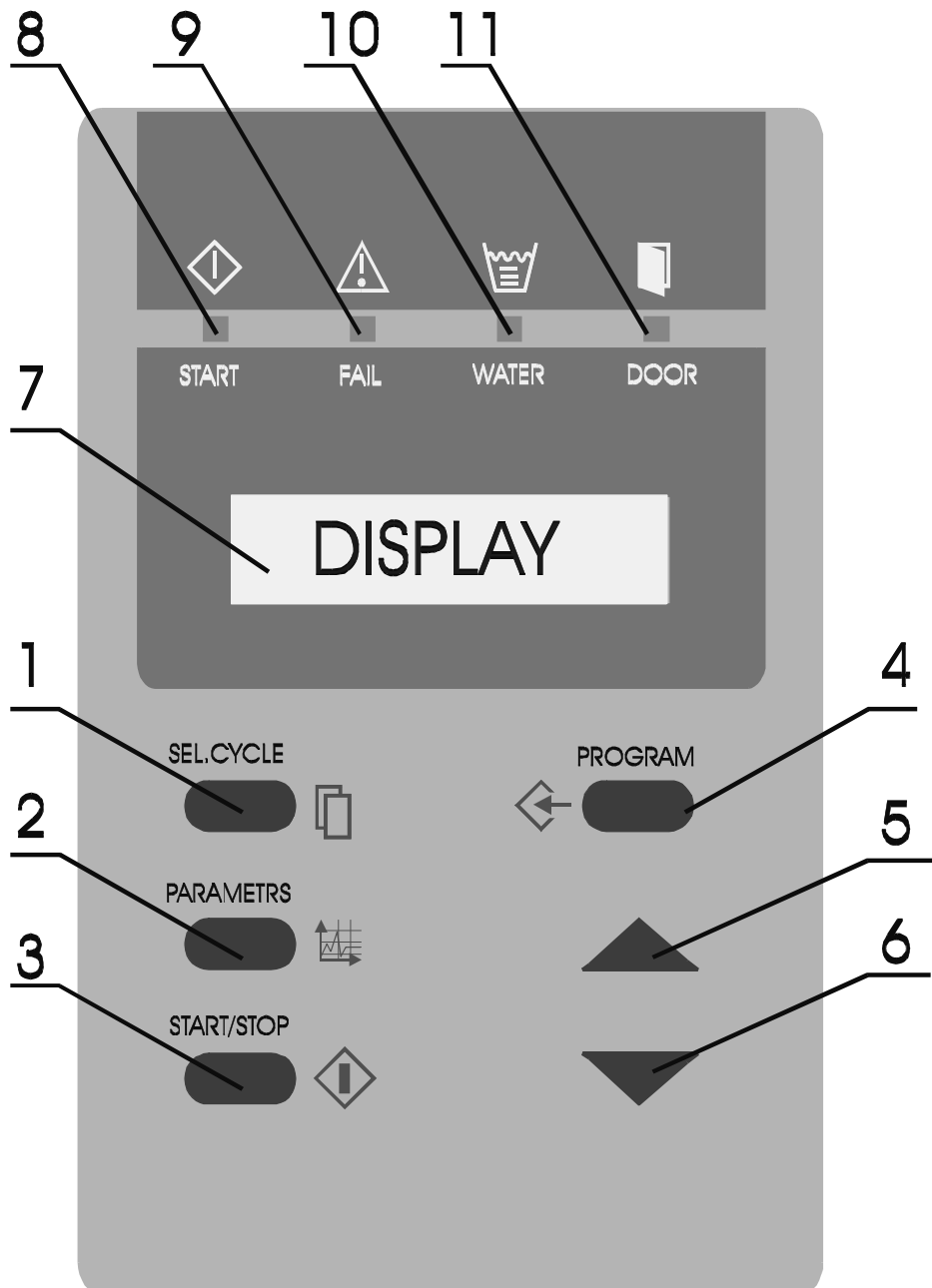

### 5.1 *Description and Functions of the Front Panel Keyboard*

The command panel is comprised of 3 sections, on the lower section there are 6 keys; 3 command keys and 3 programming keys.

The middle section consists of the LCD display with two rows and 16 characters on each line.

The top section consists of 4 signal lights that indicate the status of the autoclave.

#### 1. **Sel. Cycle (select cycle) key**



This key enables selecting the desired program out of 8 programs. Pressing this key advances the selected program to the next (e.g. from program 2 to 3).

If the system is set to program 8, pressing the key returns to program 1.

This autoclave has the following available programs:

1. Unwrapped Instruments with fast exhaust without drying 134°C / 3 minutes.
2. Instruments and materials 121°C /15 minutes with fast exhaust and 15 minutes drying.
3. Waste 121°C/20 minutes with 5 minutes drying.
4. Liquid 121°C/20 minutes.
5. Liquid 105°C/18 minutes.
6. Liquid 121°C/30 minutes with cooling (optional)

#### 2. **Parameters key**



This key displays for 3 seconds the three parameters of the program. After selecting the program, it is possible to have the parameters displayed by pressing this key; the top line reads the following data:

<b>Sterilization Temp</b>	<b>Sterilization Time</b>	<b>Dry Time</b>
<b>134°C</b>	<b>S = 3m.</b>	<b>D=1Ø</b>

The data is erased automatically after 3 seconds, or if the parameter key is pressed again during these three seconds.



### 3. **Start/ Stop key**

This key commands the following 3 functions:

- ◆ Starting the process.
- ◆ Stopping the process.
- ◆ Canceling the FAIL message from the command panel and opening the electric door locking if available.

**Note:** “STOP” does not operate in EXH stage.

#### **Starting the process:**

It is active while the autoclave is in standby position, if the door is closed and water level in the reservoir is normal, pressing this key starts the selected process.

#### **Stopping the process:**

It is active while the autoclave is in process, pressing this key at any stage of the process stops operation.

#### **Canceling the FAIL message**

The end of an aborted process, the FAIL light is turned on and an error message is displayed on the screen indicating the cause of the failure.

Pressing this key or opening the door cancels the displayed message and switches off the FAIL light.

### 4. **Program key**







This key is designed for programming the clock and setting different parameters by the service technician by means of the UP (5) DOWN (6) keys.

When the PROGRAM key is pressed, the date is displayed with the cursor under the day. Pressing the PROGRAM key again moves the cursor under the month and then on to the year.

After pressing the PROGRAM key again the time of the day will be displayed with the cursor under the hour. Pressing the PROGRAM key again moves the cursor to the minutes parameter. Each time the UP/DN key is pressed, the value of the parameter above the cursor is changed.

After the date and time parameters are set, pressing the PROGRAM key shows CODE: 000.

A code known to the technical personnel will be set to change certain parameters and perform a digital calibration of the system, as described in detail in the technician section.

5. **UP key**   
This key enables increasing the value displayed above the cursor, at the clock programming and for setting of certain parameters by the technician.
6. **DN key**   
This key enables decreasing the value displayed above the cursor, at the clock programming and for setting of certain parameters by the technician.
7. **START LED INDICATOR**   
When the “START” LED indicator is on; it indicates that the system is running a program.
8. **FAIL LED INDICATOR**   
When the “FAIL” LED indicator is on; it indicates that the cycle has failed either as a result of exceeding the allowable limits or the STOP key has been pressed.
9. **WATER LED INDICATOR**   
When the “WATER” LED indicator is on; it indicates that there is a lack of water in the reservoir.
10. **DOOR LED INDICATOR**   
If the “Start” key is pressed and the door is unlocked the light will signal twice and the buzzer will sound four times.  
If a cycle is in progress and fails on door unlocked “FAIL” LED indicator will lit and a message “Door Unlock” will be displayed.

## 5.2 *Description of the Display*

The display is built of 2 rows, each row consists of 16 characters.

### 5.2.1 *The upper row*

- ◆ ST. BY (STAND BY) – not in operation.
- ◆ HEAT – heating stage.
- ◆ STER (STERILIZATION) – sterilization stage.
- ◆ EXH (EXHAUST) – exhaust stage
- ◆ DRY (DRY STAGE) – dry stage
- ◆ WATER INLET – Water inlet stage

On the left side of the upper row, 10 characters are allotted for the selected programs.

When the PARAMETERS key is pressed; the parameter of the selected program is displayed on the upper row.

- ◆ 1-Fast Instruments – fast exhaust 134°C (273°F)
- ◆ 2-Fast Instruments – fast exhaust with dry 121°C (250°F)
- ◆ 3-Waste – slow exhaust with dry 121°C (250°F)
- ◆ 4-Liquids – slow exhaust with dry 121°C (250°F)
- ◆ 5- Liquids – slow exhaust w/o dry 105°C (250°F)
- ◆ 6-liq + Cool – slow exhaust w/o dry & with forced cooling 121°C (250°F)

### 5.2.2 *The lower row:*

- ◆ On the right side of the lower row, 5 characters are allotted for chamber pressure display.  

If pressure is displayed in kPa, the readout is 100K, for atmospheric pressure.

If pressure is displayed in PSI the readout is 00.0, for atmospheric pressure.

If the pressure is displayed in BAR, the readout will be 0.0B.

The actual pressure is continuously displayed at all stages of the process and between processes (standby).
- ◆ On the left, of the lower row the temperature is displayed; 5 characters are allotted for the display of temperature in °C, e.g. 134°C.
- ◆ In case the process is aborted, the reason for fail is displayed on the left of the lower row instead of the temperature. 11 characters are allotted for error messages.
- ◆ On completion of the process, the END message is displayed in the interval between the readouts of temperature and pressure.

- ◆ At the sterilization and dry stage, the countdown time left to completion of the stage is displayed in the interval between the readouts of temperature and pressure, on the lower row.
- ◆ The format of the display is MM:SS (two digits for minutes and two digits for seconds).

**Examples**

Example 1: Autoclave between processes, the program No.1 has been selected.



Example 2: The autoclave in the sterilization stage, program No.3 is running. Time left to completion is 3 minutes and 14 seconds.

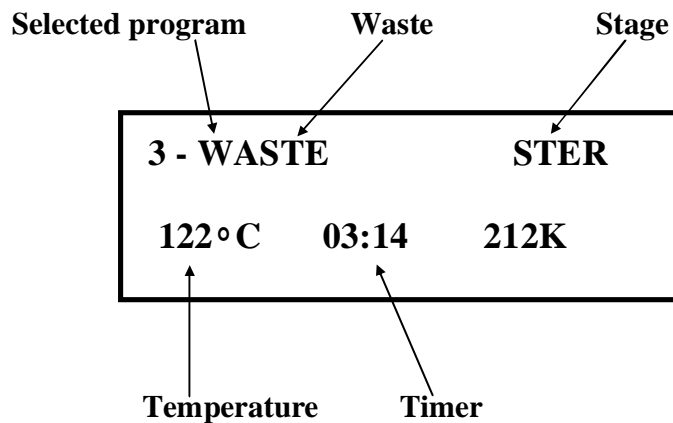

Example 3: The process failed due to temperature drop in the sterilization stage in program No.2.



### 5.3 *Description of Displayed Messages and Safety Measures*

- Low Temp.** Message is displayed, fail indicator lights and cycle is aborted, if the temperature drops for more than 5 seconds below the required sterilization temperature.
- Low Heat** Message is displayed and sterilization does not start if the autoclave has not reached sterilization temperature after heating for 60 minutes (slow exhaust program), and 30 minutes for all other programs.
- High Temp.** Message is displayed, fail indicator lights and the program is aborted:
- ◆ If the temperature rises 3°C above the required sterilization temperature during the sterilization cycle or,
  - ◆ If the temperature sensor is damaged, this message appears during the HEAT stage.
- Low Pres.** Message is displayed, fail indicator lights, and the program is aborted if the pressure drops for more than 5 seconds below the pressure correlated to the required sterilization temperature.
- High Pres.** This message is displayed, fail indicator is lit and the program is aborted, if pressure rises above the pressure correlated to the sterilization temperature +3°C- for more than 5 seconds.
- Man. Stop** Message is displayed and the FAIL indicator lights after the STOP key is pressed for longer than 1 second.
- Power Dn** If a power failure occurred during the STERILIZATION stage, but the temperature has not dropped below the sterilization temperature. When it resumes, the system automatically readjusts, this message is displayed for several seconds, the printer prints POWER DN. If temperature falls below the sterilization temperature the cycle is aborted on “LOW TEMP”.
- If the power failure occurs during the heat stage, when power resumes the system returns to the HEAT stage, the message POWER DN is displayed and printed.
- If a power failure occurred during Program 6 (slow121), the system does not allow fast exhaust (as exhaust valve is normally closed) during a power failure or when power is back on.
- If a power failure occurs during the HEAT stage, heating resumes (provided there is enough water in the chamber). If not, the cycle aborts.
- Dry and exhaust stages automatically resume operation once the power is back on.

- Door Unlock** Message is displayed and the DOOR CLOSED, LED indicator flashes if the door is improperly closed. The START button is pressed to start the desired cycle. If the door accidentally opens during any stage of the cycle, the same message and indicator appears, and the system reacts as if the STOP key was pressed.
- Electrode** Message is displayed if the water level electrode is dirty. In this case the message “clean electrode” will be printed at the end of the cycle on the printer’s output.
- No Liquids!** Message is displayed, on the bottom row, after pressing the START/ STOP key to start cycles 1 or 2 (Instruments). This message is intended to remind the operator not to sterilize liquids with these two programs. The message disappears after pressing again the START/ STOP key.

## **6     *PRINTER***

The printer is an optional device. If the autoclave is not equipped with a printer paragraph 5 is not applicable.

### **6.1   *Printer Operation***

The autoclave is equipped with a character printer, which prints a detailed history of each cycle performed by the instrument (for the record or for subsequent consideration).

The printing is made on thermal paper with 24 characters per line and contains the following information:

- ◆ Software version
- ◆ Real time
- ◆ Selected program
- ◆ Sterilization pressure
- ◆ Sterilization temperature
- ◆ Sterilization time
- ◆ Summary of performed cycle and identification hints.

When the sterilization cycle begins the printer starts printing the above data.

After the preliminary printing, the autoclave starts performing the sequence of operations of the cycle. The measured values of temperature and pressure are printed at fixed time intervals, according to the phase of the process, as shown in the table below.

The data is printed from the bottom up, beginning with the date and ending with “O.K.” for a complete cycle or “FAIL” for an aborted cycle.

For an example of a typical printout, see next page.

PRINTER OUTPUT	DESCRIPTION
Autoclave:1	Number of autoclave.
Operator : _____	To be filled in manually by operator.
11/02/2001 12:22:53	Date and time sterilization cycle ended.
Load number: 00004	Load number. Useful to determine when to clean the chamber.
Cycle ended	
----- D53:53 099.7°C 096.5k -----	The time, temperature and pressure during drying.
E48:52 100.0°C 099.1k -----	The time, temperature and pressure during exhaust.
S31:32 121.3°C 208.1k * * *	The time, temperature and pressure during sterilization.  Prints sterilization data every 1 minute.
S12:32 121.8°C 221.1k	The time, temperature and pressure during sterilization.
S11:32 121.2°C 222.3k	The time, temperature and pressure during sterilization.
----- H10:33 119.9°C 216.0k *	The time, temperature and pressure during heating.
H00:33 032.2°C 094.9k -----	The time, temperature and pressure during heating.
W00:00 027.8°C 094.5k -----	The time, temperature and pressure during water inlet.
11/02/2001 11:28:49	Date and time sterilization cycle begun.
Dry time: 005min	Drying time for selected program.
Ster time: 020min	Sterilization time for selected program.
Ster Temp: 121°C	Sterilization temperature in chamber for selected program.
PROGRAM: 4-Liquids	Selected program: 4-Liquid 121 cycle
Ver = Lab00Tn1	Number and version of the program

Legend

<b>W</b>	Water inlet stage	<b>D</b>	Drying stage
<b>H</b>	Heating stage	<b>C</b>	Cooling stage (only on program 6)
<b>S</b>	Sterilization stage	<b>k</b>	kPa
<b>E</b>	Exhaust stage		



## 6.2 DPU-20 Printer Handling

If the autoclave is equipped with a DPU-20 printer refer to this paragraph. The printer is driven and controlled automatically by the control unit, while the autoclave performs a sterilization program.

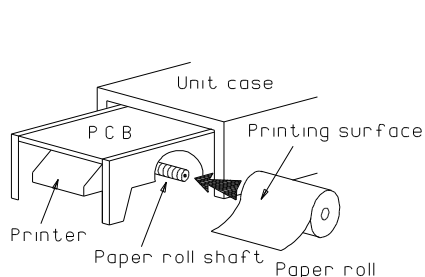

**Figure 1**

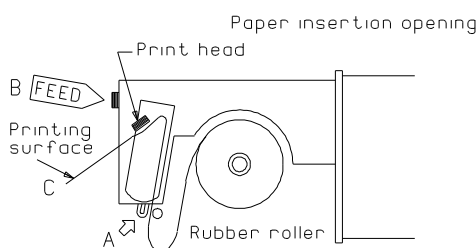

**Figure 2**

To set the paper roll in the printer perform the following steps:

- 6.2.1 Gently push the clips for removing the front panel, remove the panel and pull out the printer gently.
- 6.2.2 Set the paper roll on the shaft (See Figure 1). Since the outer and inner surfaces of the paper are different set the roll so that the printing surface is the outer.
- 6.2.3 Gently push the paper face down into insertion opening (A) in Figure 2. Keep pressing the feed switch (B) until the paper comes out from the print head (C).
- 6.2.4 When the paper emerges from the print head, insert it in the paper cutter (the slot in the front panel) and reassemble the front panel on the unit.

The paper roll is set inside the unit and the printer is ready for use..

**NOTE: If the paper is not pulled in by the rollers even when you press the feed switch (B) push the paper in.**

- 6.2.5 To ensure a reliable operation of the printer perform the following:
  - 6.2.5.1 Turn the main switch to the OFF position.
  - 6.2.5.2 Turn the main switch to the ON position; press the feed switch at the same time. Verify that the printer performs an operation test by printing all the built-in characters

**The following precautions have to be taken ensuring the proper operation of the printer:**

- ◆ Avoid contact between the paper and the hot parts of the autoclave, as the paper will be blackened.
- ◆ Do not pull out the paper roll from the paper insertion opening.
- ◆ Use only the 58mm. wide thermal paper rolls, supplied by your dealer.

## 6.3 DPU 30 Printer Handling

### 6.3.1 Setting Paper

If the autoclave is equipped with A DPU 30 printer, follow the instructions in this paragraph.

1. Press the paper cover open button, and open the paper cover.  
**Handle the paper cutter carefully not to cut your hand.**
2. Set a paper roll as shown in the figure.
3. Close the paper cover by pressing both ends of the cover with the tip end of the paper emerging from the cutter.

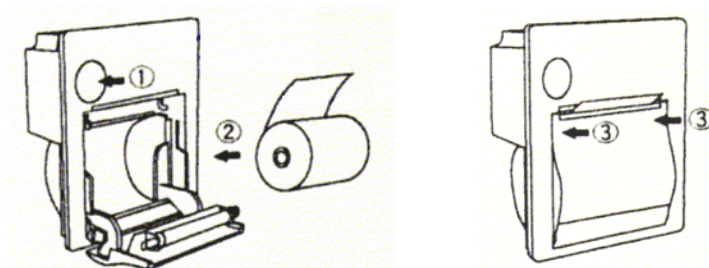

### 6.3.2 Maintenance

1. Wipe off the soiling on the printer surface with a dry soft cloth with a weak neutral detergent. After that, wipe the printer with a dry cloth.
2. **Caution:** Never disassemble the printer. Failure to follow this instruction may cause overheating or burning of the printer or the AC adapter. Or an electric shock, which may lead to fires or accidents.
3. Never use the printer in a place of extreme humidity or any place where it can possibly be splashed by any liquids. If any liquids get into the printer, it could lead to fire, electric shock, or other serious accidents.
4. Never touch the thermal head immediately after printing because it becomes very hot. Make sure that the thermal head is cool before setting papers or cleaning the thermal head.
5. Power OFF the printer in any of the following cases:
  1. The printer does not recover from an error.
  2. Smoke, strange noise or smells erupt from the printer.
  3. A piece of metal or any liquid touches the internal parts or slot of the printer.
6. Notes on treatment of thermal papers:
  1. Store the papers in a dry, cool and dark place.
  2. Do not rub the papers with hard substance.
  3. Keep the papers away from organic solvent.

## 7 **PREPARATION BEFORE STERILIZATION**

The purpose of packaging and wrapping of items for sterilization is to provide an effective barrier against sources of potential contamination in order to maintain sterility and to permit aseptic removal of the contents of the pack. Packaging and wrapping materials should permit the removal of air from the pack, penetration of the sterilizing water vapor into the pack and removal of the sterilizing vapor.

The basic principle determining the size, mass and contents of instrument and hollowware packs is that the contents are sterile and dry immediately on completion of the drying cycle and removal of the pack from the sterilizer chamber.

Instruments to be sterilized must be clean, free from any residual matter, such as debris, blood, pads or any other material. Such substances may cause damage to the contents being sterilized and to the sterilizer.

1. Before use, check inside the autoclave chamber to ensure that no items have been left from the previous cycle.
2. Immediately after use, clean instruments thoroughly to dispose of any residue.
3. It is recommended to wash instruments with an ultrasonic cleaner, using detergent and mineral-free water.
4. Launder textile wraps prior to reuse.
5. After cleaning, rinse instruments for 30 seconds. (Follow manufacturer's instructions on the use of products for cleaning and lubricating instruments after using the ultrasonic cleaner).
6. Materials, including materials used for inner wraps, shall be compatible with the item being packed and the sterilizing method selected.
7. Do not place materials to be sterilized directly on the chamber's wall. Place the material only on trays, rack, etc.
8. Before placing an instrument on the sterilizer tray, make sure that instruments which are not of the same metal, (stainless steel, carbon steel, etc.) are separated and placed on different trays.

### **Note:**

**Check manufacturer's instructions for the sterilization of each item.**

9. In case carbon steel instruments are placed on the stainless steel tray, the tray should be lined with a towel or paper wrap before placing the instruments on the tray. There should be no direct contact between the carbon steel and the stainless steel tray.

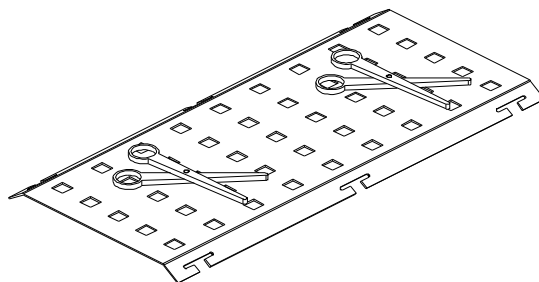

10. All instruments must be sterilized in an open position.

11. Use single-use wraps once only and discard after use.
12. Place a sterilization indicator strip on the tray.
13. Place instruments with ratchets opened and unlocked or clipped on the first ratchet position.
14. Disassemble or sufficiently loosen multiple-part instruments prior to packaging to permit the sterilizing agent to come into contact with all parts of the instrument.
15. Tilt on edge items prone to entrap air and moisture, e.g. hollowware, so that only minimal resistance to removal of air, the passage of steam and condensate will be met.
16. Load items within the boundaries of the tray so that they do not touch the chamber walls.
17. The operator may use racks to allow for adequate separation of packaged instruments.
18. Load trays in such a way as to allow steam to move freely among all items.
19. Once a week, use a biological spore test indicator in any load to make sure sterilization is performed efficiently.
20. Make sure that all instruments remain apart during the sterilization cycle.
21. Empty canisters should be placed upside-down, in order to prevent accumulation of water.

**22. *Wrapped Instruments***

1. Wrapped instruments should be packed in material that promotes drying such as autoclave bag, autoclave paper, and muslin towels.

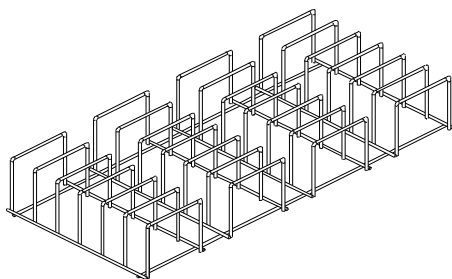

**For model 2540**

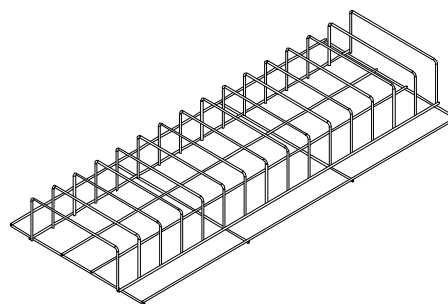

**For model 3870**

2. It is highly recommended to utilize the Tuttnauer™ Pouch Rack. This rack allows the operator to place pouches on their side, thus increasing the capacity of the autoclave significantly and promoting better drying of the instruments. Contact your dealer for details.
3. Verify that the packaging method is in accordance with good practice approach and the packaging materials are in accordance with the applicable standards (e.g. EN868 series).

23. **Packs**

1. Place packs upright on the tray, side by side.

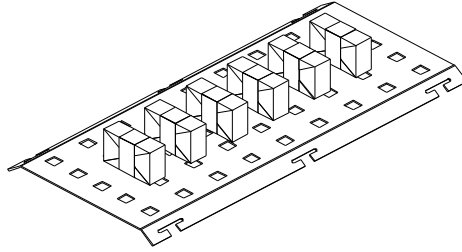

2. Packs should not touch the chamber walls.
3. Pack instrument sets in a manner that prevents damage to delicate items.
4. Pack hollowware sets so that all openings face the same direction and so that the contents cannot move inside the pack.
5. Load packs of folded operating room drapes with layers vertical, allowing air to be removed from the packs rapidly.
6. Do not place packs of hollowware and trays of instruments above textile packs or soft goods in order to avoid wetting caused by condensation from items above.
7. Load items packed in flexible packaging materials on edge with paper to laminate, or flat with the paper surface downwards.

**Note:**

**The manufacturer's recommendations shall be observed, concerning the sterilization data for each type of material.**

24. **Tubing**

When placing tubing on the tray, make sure that both ends are open, without sharp bends or twists.

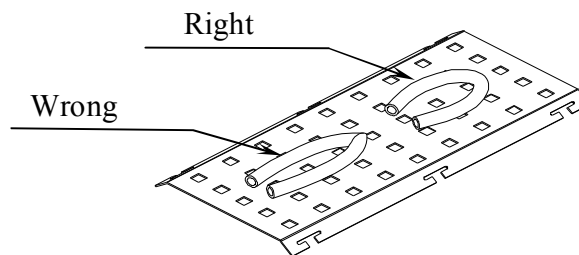

25. **Sterilization of Liquids**

Use only heat-proof glass, filled 2/3 full.

Ensure that the glass container is covered but not sealed to prevent pressure build-up.

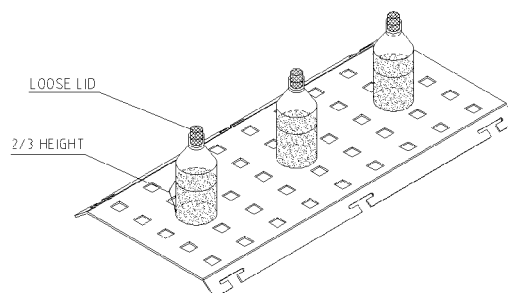

## 7.1 *Filling the Water Reservoir*

### 7.1.1 *Models 2540, 3150, 3850, 3870*

Remove the water reservoir cover. Pour distilled water into the reservoir through the opening on top of the autoclave until it reaches the base of the safety valve holder. The water quantity for 2540 is approx. 3 liters (0.66 US gal.) and for models 3150, 3850, 3870 is approx. 7.1 liters (1.56 US gal.).

Use only water having the characteristics as per table in para. 2.13. Tap water may clog the system. A clogged system causes increase of pressure, which prevent temperature from rising.



#### **Caution!**

***Under no circumstance should water be filled above the safety valve holder.***

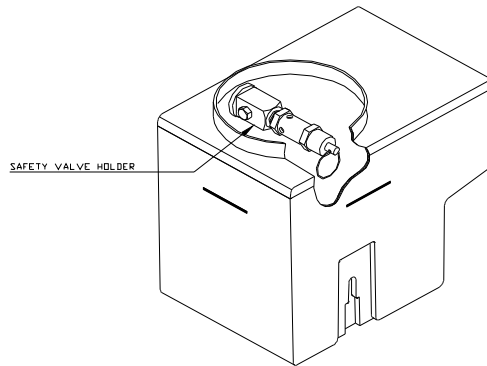

### 7.1.2 *Models 5050, 5075*

Remove the water reservoir cover. Pour distilled water into the reservoir through the opening on top of the autoclave until it reaches the level of approximately 1÷2 cm (0.5”÷0.75”) below the outlet of the return tube. The water quantity is 16÷17 liters (4.2÷4.5 US gal.).

Use only water having the characteristics as per table in para. 2.13. Tap water may clog the system. A clogged system causes increase of pressure, which prevent temperature from rising.



#### **Caution!**

***Under no circumstance should water be filled above the level defined above.***

## 8 OPERATING INSTRUCTIONS

### 8.1 Operation



**To avoid possible damage, do not leave the autoclave un-attended while in operation**

1. Remove the water reservoir cover. Pour distilled water into the reservoir through the opening on top of the autoclave.
  - ◆ **Models 2540, 3150, 3850, 3870**  
Fill water until it reaches the base of the safety valve holder (for water quantity, refer to tables on paragraphs 2.9, 2.10).
  - ◆ **Models 5050, 5075**  
Fill water until it reaches the level of approximately 1÷2 cm (0.5”÷0.75”) below the outlet of the return tube. The water quantity is 16÷17 liters (4.2÷4.5 US gal).
2. Insert the plug into the socket.
3. Turn on the rocker switch mounted on the front panel to power the control circuits.
4. Set the clock for the proper date and time, by means of the PROGRAM key (4), UP (5) and DOWN (6); see section 4.
5. Press the SELECT key (1) to select the required program. The name of the program is displayed indicating the program has been selected.
6. Press PARAMETERS key (2) to monitor the nominal parameters of the program.
7. If the autoclave is equipped with a printer verify that a paper roll is inserted in the printer. If not - insert as per para. 5.2.
8. Load the material to be sterilized into the chamber, and close the door.

**Note (for models 2540, 3140, 3850, 3870):**  
**Due to inherent elasticity of the door gasket, the DOOR LED indicator may indicate that the door is closed before a complete seal is made between the door and the chamber.**  
**Therefore, in order to ensure the door is fully sealed, continue to tighten the door bolt until “hand-tight”. Do not over - tighten the bolt as this may result in damage to the gasket.**  
**Should the autoclave fail to reach the sterilizing temperature / pressure, always check if the door is fully sealed. If not, tighten the door bolt further, as described above, until completely sealed.**
9. Verify once again that you have chosen the appropriate sterilization program.
10. Press the START/ STOP key to begin the cycle. If program 1 or 2 were selected a warning message "No Liquids!" will be displayed on the bottom row. After verifying that the load is not liquids, press again the START/ STOP key to start the cycle.
11. The autoclave starts performing sequence of operations. The actual measured values of pressure and temperature are displayed continuously and printed every minute at STE stage, and every 5 minutes at the other stages. The phase in progress is displayed at the right side of the upper line as WATER, HEAT, STER., EXH., and DRY.

If the operator presses the START key and the door is not completely closed, the process will not start and the DOOR indicator will flash twice then turn off and the buzzer will sound four times.

### CAUTION



**Do not touch the strainer's cover, mounted on the exhaust line, during and short after operation.**

**Touching the hot strainer's cover may cause severe injuries.**

### NOTE

**At first operation of models 5050, 5075, when operated from cold start, a few milliliters of water may accumulate in the "C" shape frame of the door. This is normal and results from condensed steam.**

12. At the end of the cycle, the START light is put off, the END message is displayed and the buzzer will ring a continuous sound for 7 seconds. In case of a failed cycle, the diagnosis of the failure followed by the "FAIL!!!" message will be printed and the buzzer will output an interrupted sound.
13. Open the door and unload the sterilized material from chamber.
  - 13.1 For models 2540, 3150, 3850, 3870, in case of fail press the START/STOP key to cancel the locking of the door.
  - 13.2 For models 5050, 5075, to release the door locking at the end of operation, press the UP key. The same applies at power up after fail. Rotate the handle counter-clockwise to pull out the locking arms from the retaining brackets.

For unloading hints – see para. 7.2.3 (Unloading).
14. At the end of each working day close the main water valve.

## 8.2 *Loading and unloading the Device*

### 8.2.1 *Safety*

Protective equipment and clothes and other safety instructions should be implemented in accordance with local and national regulations and/or rules!

For proper sterilization - Do not overload the chamber. Only autoclavable products shall be used; please refer to the manufacturer instructions for sterilization of unknown materials or instruments.

### 8.2.2 *Loading*

Correct loading of the autoclave is essential to successful sterilizing for several reasons. Efficient air removal from the chamber and the load will permit total steam penetration and saturation, and allow proper drainage of condensate. Additionally, correct loading will reduce damage to packs and their contents and maximize efficient use of the sterilizer.

For detailed loading instructions, see para. 7 (Preparation before sterilization)



### 8.2.3 *Unloading*

On completion of the cycle, take out the load immediately from the sterilizer. Do not remove the load from the tray until its temperature reduces to the room temperature. Let the load cool down in an area without air movement (air conditioning, etc.) and with minimum people passing by to avoid possibility of touching the hot load. Do not touch the hot load since hot load absorbs moisture and, therefore, may absorb bacteria from your hand. Do not transfer hot load to metal shelves for cooling. Perform a visual inspection to ascertain that sterilizing indicators have made the required colour change, and that the load is dry.

The load shall be rejected if:

- a. The package has been compressed.
- b. The package is torn.
- c. The load is suspected to be wet.
- d. The load fell on the floor.
- e. Condensed drops can be detected on the load.



**To avoid injuries use heat resistant gloves while unloading the autoclave.**

## 9 MAINTENANCE INSTRUCTIONS

### 9.1 Preventive and Scheduled Maintenance

The maintenance operations described in this chapter have to be fulfilled periodically to keep the device in good condition and to reduce the breakdown time to a minimum.

The user maintenance personnel can easily execute these operations in accordance with further instructions.

The owner of the autoclave is responsible to order an authorized technician to perform the periodical tests and preventive maintenance operations, as specified in the technician manual.

Use only mineral-free water as detailed in para. 2.13 (water quality).

#### **Warning:**



**Before carrying out any preventive maintenance operation, ensure that the electrical cord is disconnected and that there is no pressure in the autoclave.**

#### 9.1.1 Daily

Clean door gasket with a soft cloth. The gasket should be clean and smooth.

#### 9.1.2 Weekly

1. Once a week clean and descale the chamber, copper tubes and the reservoir using 'Chamber Brite™' (see para. 9.9).



#### **Caution**

**Do not use steel wool or steel brush as this can damage the chamber!**

2. Put a few oil drops on the 2 door pins and door tightening bolt.
3. Clean the outer parts of the autoclave with a soft cloth.
4. Once a week, or after 20 cycles (whichever comes first), drain the water from the reservoir, and refill with fresh mineral-free water or distilled water (see para. 9.2).
5. Clean the electrode with a soft cloth.

#### 9.1.3 Periodically

1. On models ELC replace the air filter, every 6 months (to be performed by a technician).
2. Check the door gasket every 12 months and replace it if required (see para. 9.5). Replacing the gasket of models 5050, 5075 shall be done by a technician.
3. Once a year check and tighten the piping joints to avoid leakage.
4. Once a year check and tighten all screw connections in the control box, heaters and valves and instrumentation.
5. Once a month clean the strainer as per para. 9.3. Cleaning frequency may be reduced according to experience.
6. Once every six months clean the fan grid, from the inside outward, with a vacuum cleaner.

#### 9.1.4 Periodical Tests

1. Once every month activate the safety valve (see para. 9.4).

## 9.2 *Draining the Reservoir*



### **Caution!**

**Before starting, Make sure that the electric cord is disconnected and there is no pressure in the autoclave.**

1. Connect the supplied plastic tube and turn drain valve counter clockwise (1 turn).
2. When the water reservoir is empty, turn drain valve clockwise to the clockwise position. Remove the plastic tube.
3. Fill reservoir with distilled water until it reaches the base of the safety device holder (for water quantity, refer to tables on paragraphs 2.9, 2.10).
4. Connect the electric cord to power source.

The autoclave is now ready for use.

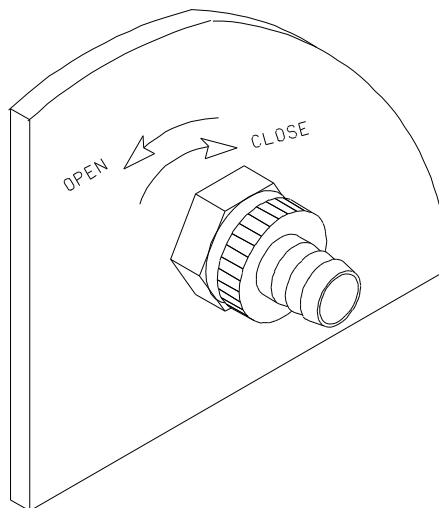

### 9.3 *Cleaning water strainer*



#### **Caution!**

**Before proceeding, Make sure that the electric cord is disconnected and there is no pressure in the autoclave.**

1. Open the strainer cover.
2. Remove the strainer element.
3. Rinse the strainer with water. Use a brush if necessary.
4. Reinstall the strainer element.
5. Close the strainer cover.

#### **Caution!**

**Do not touch the strainer's cover, mounted on the exhaust line, during and short after operation.**

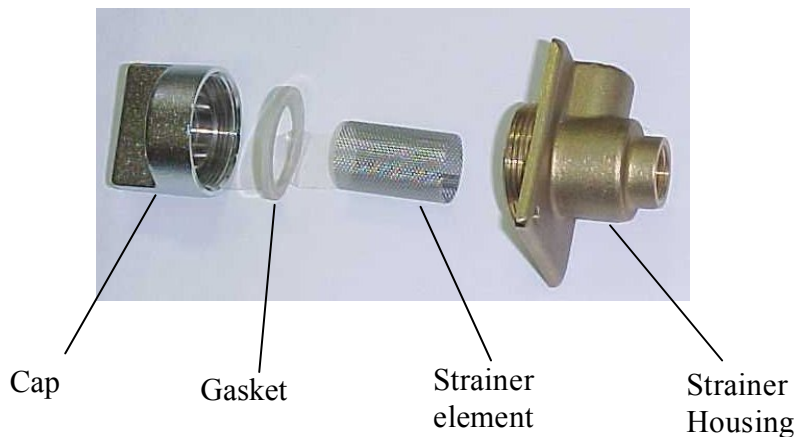
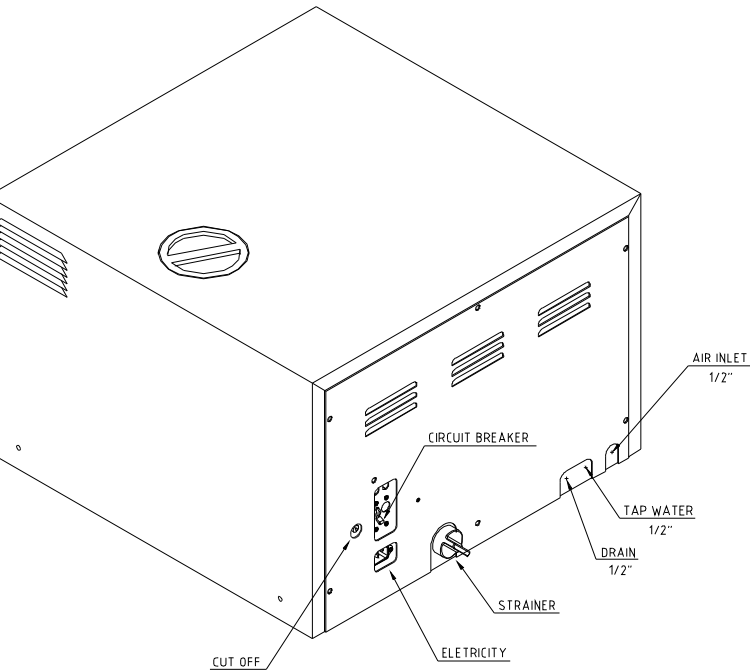

## 9.4 Checking the Safety Valve

In order to prevent the safety valve from blockage, it is necessary to allow the steam pressure to escape through it (every month).

On models 2540, 3150, 3850, 3870 the safety valve is located in the water reservoir.

On models 5050, 5075 the safety valve is located in the rear top side of the autoclave.

### 9.4.1 PED-approved type safety valve

1. Operate the sterilization cycle according to the manual.
2. Allow a pressure of approx. 200 kPa (29-psi) to build up in the chamber.
3. On models 2540, 3150, 3850, 3870 Remove the water reservoir cover.
4. Turn the pressure relief nut counterclockwise for 2 seconds. Verify steam escapes from the valve.



#### Attention:

*Use protective gloves in order not to burn your hands with the hot steam.*

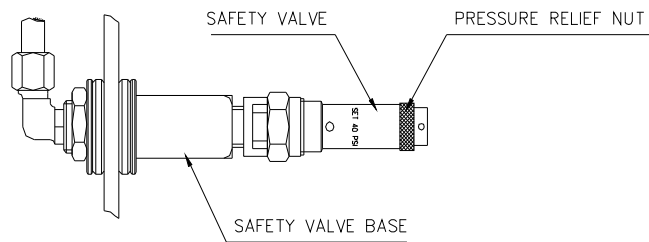

**For models 2540, 3150, 3850, 3870**

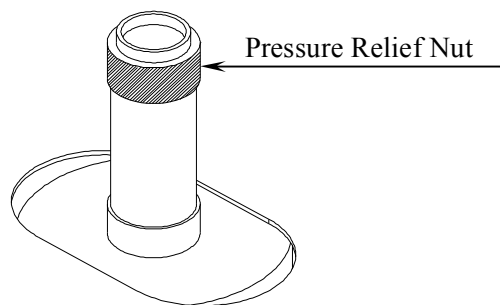

**For models 5050, 5075**

5. Press the STOP key to interrupt the operation, and exhaust steam from the chamber.
6. Wait until the pressure decreases to zero, only then can the door be opened.

#### 9.4.2 ASME-approved type safety valve

1. Operate the sterilization cycle according to the manual.
2. Allow a pressure of approximately 200 kPa (29-psi) to build up in the chamber.
3. Remove water reservoir cover
4. Operate the safety valve:
  - 4.1 On models 2540, 3150, 3850, 3870 pull the ring of the safety valve using a tool, i.e. screwdriver, hook etc and lift the safety valve ring for 2 seconds. Be careful not to burn your hands.
  - 4.2 On models 5050, 5075 pull the valve's handle and verify that steam escapes from the valve.
5. Press the STOP key to pause operation, and exhaust steam from chamber.
6. Wait until pressure goes down to zero, only then can the door be opened.



#### **Attention:**

**Use protective gloves in order not to burn your hands with the hot steam.**

5. Press the STOP key to interrupt the operation, and exhaust steam from the chamber.
6. Wait until the pressure decreases to zero, only then can the door be opened.

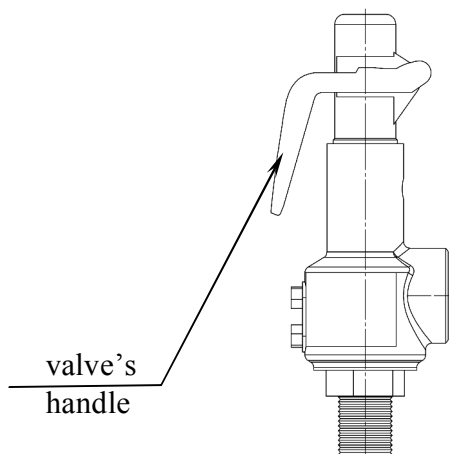

**For models 5050, 5075**

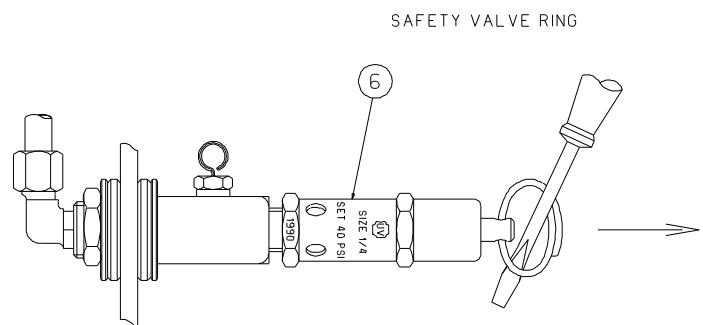

**For models 2540, 3150, 3850, 3870**

### 9.5 Replacing the Door Gasket

For models 2540, 3150, 3850, 3870

(Gaskets of models 5050, 5075 shall be replaced by a technician. See technician manual)

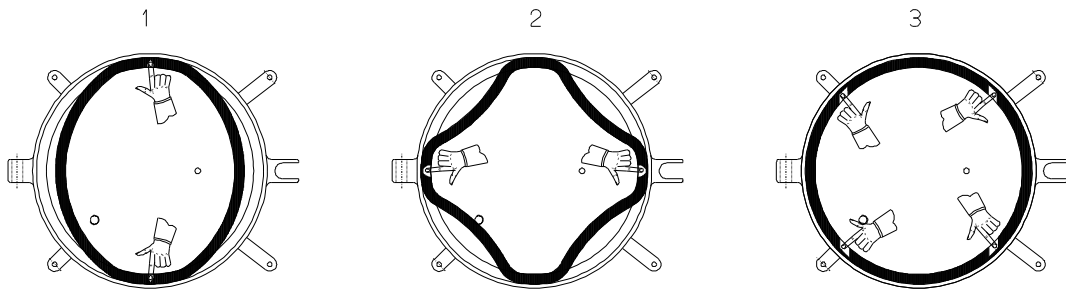

Pull off the gasket from the door groove and install the new gasket referring to the drawings as above points 1, 2 and 3.



#### Caution!

This gasket is designed with a trapezoidal cross section. The gasket should be placed with the widest side towards the door.

## **9.6 Door Safety System for models 2540, 3150, 3850, 3870**

The door opening is ensured by two means:

1. The closing device prevents an incidental opening of the door.
2. A pull-type solenoid, which is in inactivated position, locks the door and must be electrically powered to release the locking and enable the opening of the door.

### **9.6.1 Solenoid locking device**

The solenoid locks the door in the following situations:

1. When the control unit is not powered.
2. If power failed or has been turned off while the autoclave is in operation, even if power has been restored.
3. If operation was stopped before completion of the cycle as a result of a failure or a manual stop.
4. When the temperature inside the autoclave chamber is higher than the “end of cycle” temperature, preset by the operator; the opening of the door is possible only when the temperature has dropped below preset value.

For cases described at points 2 and 3, press the START/STOP key to cancel the door locking at the end of the operation.

If, for any reason, the locking mechanism does not open, call for Tuttnauer service.



**Warning!**

**Do not use force to open the door.**



## 9.7 *Door Safety System for models 5050, 5075*

### 9.7.1 *Door Components*

- A circular frame with a “C” cross section is welded on the topside of the vessel. When the door is closed it lays on the “bottom leg” of the frame.
- The door plate mechanism consist the following:
  - a. A centric shaft welded to the doorplate (2).
  - b. An arm housing (3) that holds the 8 arms and is able to swivel on a thrust bearing. The housing is secured.
  - c. Bakelite handle (4), which is operated by the operator, is installed directly on the housing.
  - d. 8 arms (5), which are held in the arm housing in such a way that they, are rotatable. These arms are freely located in a guide (6), which enable them to move in an angular movement due to the rotation of the arm holder.

**Note:** the drawing provided below describes the door in the “locked” position: The handle is positioned in 10:00-4:00 (hour) angle, and the arms are pushed radially into the circular frame.

The “open” position is when the handle is located in 7:00-1:00 (hour) angle. In this position the arms are retracted from the circular frame due to the rotary movement of the arm holder to a position which is described in dotted lines.

### 9.7.2 *Safety means*

The door is equipped with three safety means as follows:

#### 9.7.2.1 *Locking solenoid (7)*

This solenoid is a “Normally pushed” pin type and is located on an adjustable base (8). The solenoid’s pin is spring loaded in such a way that when it is not activated, the pin is pushed out.

A bracket with a hole is attached on the arm holder. The hole is located in such a way that the solenoid pin, when pushed, will be trapped in the hole.

An inclined tongue is welded to the bracket. This tongue assists the pin to retract when the locking mechanism is turned to the “unlocked position”. When the pin is in the “locking position” it prevents the arm holder from any angular movement.

### 9.7.2.2 *Safety locking microswitch (10)*

This microswitch is activated when the arms are in a radial – “locked” position.

The microswitch signal one of the following:

- a. Arms are locked – cycle can be activated
- b. Arms are in a non-locked position. It is impossible to start a cycle and the door can be opened.

### 9.7.2.3 *DOOR CLOSED microswitch (13)*

This microswitch is located under the circular frame (1) and has an activating rod piercing through the frame. When the door is closed it presses the micro-switch’s rod. At this stage the microswitch sends a signal that the door is closed.

The two micro-switches (10 and 13) ensure that operation cannot be started if autoclave door is unlocked. When the two micro-switches are activated, the light “Door Closed” on the keyboard panel is ON and operation can be initiated.

SAFETY DOOR DEVICE  
MODELS: 5050, 5075

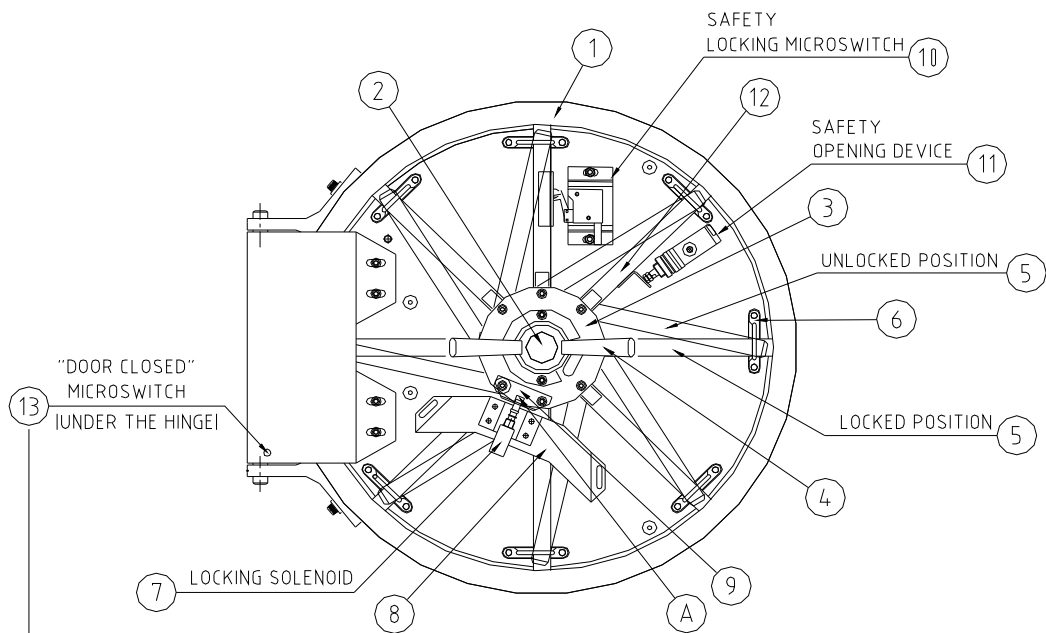

#### **9.7.2.4 Safety opening device (11)**

This Safety device is a 3/2 operating pneumatic spring loaded valve (2 position, 3 ports) that is connected to the safety port of the door. An angular bracket (12), which is attached to one of the arms, will push the valve's piston to a position that at the instant that the arms are locked, the safety port of the door is blocked.

At the instant that the arms moves backward the valve changes its position and the chamber is vented. After the pressure in the chamber equalizes the ambient pressure the autoclave's door can be opened with no risk for the operator, of steam or hot water burst.

### **9.7.3 Safety Process Description**

9.7.3.1 The user closes the door and rotates the handle clockwise aprox. 90°

- a. At the end of the circular movement of the arms holder, the pin of the locking solenoid slides to its locking position.
- b. When the arms moves the last radial 15 mm, one arm activate the microswitch, while another arm (on which there is the angular bracket) pushes the piston of the 3/2 valve to a position that the venting port of the door is blocked.

9.7.3.2 The user start a sterilization cycle by pressing a "start" key on the operating panel.

9.7.3.3 Cycle completion.

There are 6 sterilization programs:

- a. Program 1 and 2 will end if the cycle is completed and the pressure in the chamber is below 115 kPa (abs).
- b. Programs 3 to 6 will end if the cycle is completed, the pressure decreases below 115 kPa (abs) and the chamber temperature decreases below 85°C.

9.7.3.4 After all completion conditions are fulfilled, the operator must rotate the handle a little bit counterclockwise to activate the microswitch (10).

Activating the microswitch will cause the "door" light to flash a few times.

When the first step of opening the door is performed and arms are unlocked turning the handle counterclockwise, the arms change direction, the piston is

released and valve opens, chamber is aerated and residual pressure discharged from the chamber.

This way, the second step, opening the door by pulling it, can be done safely, with no risk for the operator, of steam or hot water burst.

After the "door light" had signaled the operator will press the "up" key and the solenoid will retract.

At this stage the unlocking operation is completed and the operator can open the door.

## 9.8 *Cleaning Table Top Autoclaves with Chamber Brite™*

CHAMBER BRITE™ is a cleaning and descaling agent designed specifically for the cleaning and removal of water deposits, oxides and other sediments that are found in steam sterilizers. The material is a combination of acidic salts and additional cleaning materials.



### **Cleaning Procedure**

1. Important – all steps in this procedure must be completed without Interruption.
2. When the autoclave chamber is cold, remove instruments and tray from the autoclave.
3. Open the door and spread the contents of a packet in a straight even line along the bottom of the chamber, from back to front.
4. Select and start program 1. When the cycle is finished exhaust the unit.
5. At the end of the exhaust cycle drain the water from the reservoir.
6. Fill the water reservoir with distilled water.
7. Repeat a sterilization cycle without Chamber Brite™ powder, to remove any excessive dirt in the pipes. Select and start program 1. When the cycle is finished exhaust the unit
8. At the end of the exhaust cycle drain the water from the reservoir.
9. Turn the autoclave off and allow chamber to cool.
10. Wipe the interior of the chamber with



a damp cloth.

11. Fill the reservoir with distilled water or mineral free water only.
12. Press the manual water fill button and allow a small amount of water (2-4 ounces) to fill chamber. Remove water from chamber.
13. The instrument is ready to use.

**IMPORTANT:**

**DO NOT sterilize instruments during the cleaning process!!!**

**CAUTION:**

**Keep out of reach of children. Contains mildly acidic ingredients. Avoid contact with the skin, eyes or clothing. Wash hands well after touching the powder, in the case of eye contact flush with continuous running water for at least 15 minutes. If irritation persists get medical attention. If accidentally swallowed, do not induce vomiting, drink large amounts of water and obtain medical attention. MSDS available upon request.**

For models 2540 use one packet of CHAMBER BRITE™.

For models 3150, 3850, 3870 use two packets of CHAMBER BRITE™.

For models 5050, 5075 use three packets of CHAMBER BRITE™.

Clean every 20 cycles or as needed.

## 10 TROUBLESHOOTING

Only technical personnel having proper qualifications and holding technical documentation (including a technician manual) and adequate information are authorized to service the apparatus beyond operations described below.

<i>Problem</i>	<i>Solution</i>
1. The machine is not responding	<p>1.1 Check the outlet at the facility and verify that voltage requirements of the unit have been met, including phase.</p> <p>1.2 Make sure the main switch is in the 'On' position. (see front view drawing).</p> <p>1.3 Make sure the power cord is properly connected to the machine and the mains. (see rear view drawing)</p>
2. 'Low Heat' is displayed	2.1 Make sure the machine has the proper amount of sterilization load (not over loaded)
3. 'Low Water' is displayed	<p>3.1 Verify that there is water in the reservoir. Add if required.</p> <p>3.2 Clean the water level electrode inside the vessel.</p> <p>3.3 Check the leveling of the machine.(see para. 6, Installation).</p>
4. 'Low Pres' is displayed	<p>4.1 Verify that no instruments are in contact with the water level electrodes.</p> <p>4.2 Check the door for leakage and replace the door gasket if necessary. (see para. 9.5 Replacing the Door Gasket)</p>

<b>Problem</b>	<b>Solution</b>
5. 'High Temp' is displayed	Clean the water level electrode inside the vessel. 5.2 Check levelling of the machine. (see para. 6, Installation)
6. 'High Pres' is displayed	6.1 Clean the water level electrode inside the vessel. 6.2 Check the levelling of the machine. (see para. 6, Installation)
7. The machine is leaking at the door.	7.1 Make sure the door is tightened enough. Replace the door gasket if required. (see para. 9.5 Replacing the Door Gasket)
8. Water does not exit chamber due to clogged outlet strainer.	8.1 Clean strainer according to instructions.
9. The printer prints, but nothing is printed on the paper.	9.1 Make sure the paper is mounted in the right way. Only one side of the paper is printable. (see para. 5.2., Printer handling)
10. The printer does not print.  If the autoclave is equipped with a printer	10.1 Make sure the paper is inserted in the printer. (see para. 5.2, Printer handling) 10.2 Switch off the machine and switch it back on while pressing the feed button on the printer. If the printer prints a test printout, the printer is O.K. and there is a problem with the electronics. Contact your dealer to solve the problem. If the printer does not print the test printout, there is a problem with the printer. Contact your dealer to solve the problem.
11. When the machine is switched on, the printer feeds paper continuously.	11.1 Make sure the 'feed button' on the printer is not stuck.

<i>Problem</i>		<i>Solution</i>
<p>If the autoclave is equipped with a printer</p>	<p>12. You cannot change the program and the FAIL light remains on.</p>	<p>12.1 A problem with the printer paper often prevents the operator from changing programs. To rectify the problem, perform the following:</p> <ul style="list-style-type: none"> <li>— Turn off the main switch.</li> <li>— Remove the printer paper as described in the Chapter on “Printer Handling”.</li> <li>— At this point the no paper indicator on the printer lights.</li> <li>— Turn the main switch on. The cycle should return to the previous stage.</li> <li>— At this point insert the printer paper, verifying that it is inserted properly.</li> </ul> <p>If the cycle does not return to its former stage, the technician will perform a memory reset.</p> <ul style="list-style-type: none"> <li>— After performing a reset, insert the printer paper with care.</li> </ul>

**If the above recommendations did not correct the malfunction, or if any problems not discussed in this section were encountered, please contact an authorized technician.**

**POUCH RACK**



**For model 2540 - ACS215-0008**

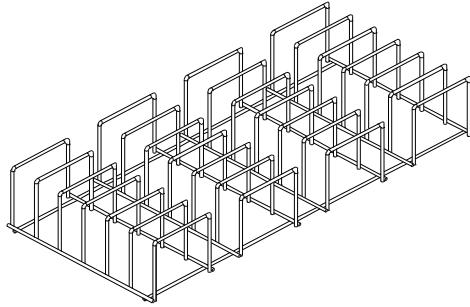

**For model 3870- TRH387-0006**

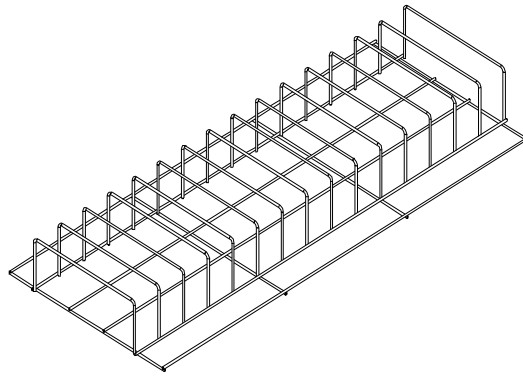

**TRAY - standard**

<b>MODEL</b>	<b>CAT. No.</b>
2540	TRY254-0001
3850	TRY385-0006
3150	TRY315-0001
3870	TRY387-0006
5050	TRY505-0001
5075	TRY507-0001

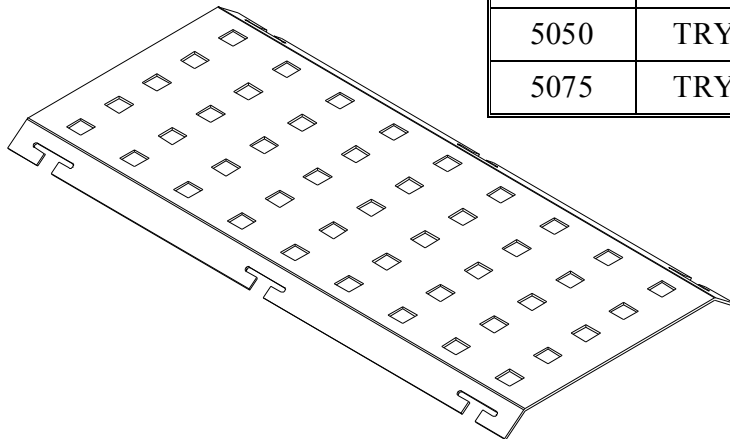

**TRAY, Special ELC version**

MODEL	CAT. No.
2540	TRY254-0001

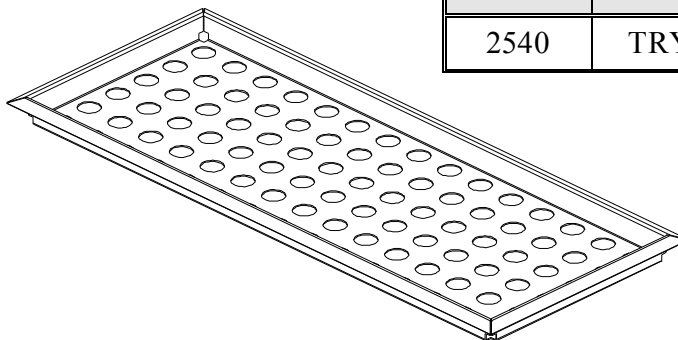

**TRAY HOLDER, Special ELC version**

MODEL	CAT. No.
2540	TRH234-0001

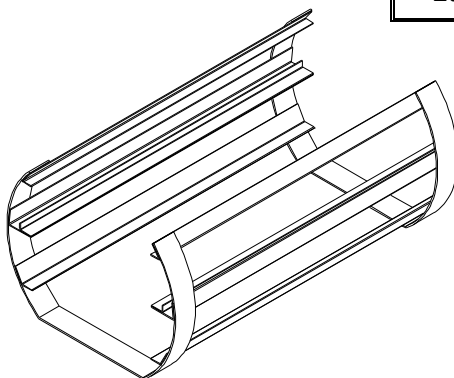

## BASKETS AND CONTAINERS



**Basket**

**Container for waste products**

Model	Stainless steel wire baskets		Stainless steel container for waste products	
	L x D x H (mm)	Capacity	L x D x H (mm)	Capacity
<b>2540</b>	400 x 170 x 140	1	400 x 170 x 140	1
<b>3150</b>	500 x 210 x 185	1	500 x 210 x 185	1
<b>3850</b>	500 x 260 x 225	1	500 x 260 x 225	1
<b>3870</b>	680 x 260 x 225	1	680 x 260 x 225	1
<b>5050</b>	500 x 380 x 250	1	500 x 380 x 250	1
<b>5075</b>	715 x 380 x 250	2	715 x 380 x 250	2

## 11 SPARE PARTS LIST

<i>Description</i>	<i>Cat. No.</i>					
	<i>2540</i>	<i>3150</i>	<i>3850</i>	<i>3870</i>	<i>5050</i>	<i>5075</i>
Strainer element, 400µ	FIL175-0046	FIL175-0046	FIL175-0046	FIL175-0046	FIL175-0046	FIL175-0046
Cap for 1/4" strainer	FIL175-0027	FIL175-0027	FIL175-0027	FIL175-0027	FIL175-0027	FIL175-0027
Door gasket	GAS080-0003	GAS080-0029	GAS080-0004	GAS080-0004	—	—
Teflon gasket 4mm	GAS082-0008	GAS082-0008	GAS082-0008	GAS082-0008	GAS082-0008	GAS082-0008

## 12 ACCESSORIES LIST

<i>Description</i>	<i>Cat. No.</i>						
	<i>2540</i>		<i>3150</i>	<i>3850</i>	<i>3870</i>	<i>5050</i>	<i>5075</i>
	<i>Special ELC</i>	<i>Standard</i>					
Pouch rack	ACS215-0008	ACS215-0008	—	—	ACS215-0008	—	—
Chamber Brite™ 1 box (10 packets)	CLE096-0026	CLE096-0026	CLE096-0026	CLE096-0026	CLE096-0026	CLE096-0026	CLE096-0026
Pinter	DPU20	THE002-0005	THE002-0005	—	—	—	—
	DPU30	—	—	THE002-0022	THE002-0022	THE002-0022	THE002-0022
Printer paper	DPU20	THE002-0003	THE002-0003	—	—	—	—
	DPU30	—	—	THE002-0025	THE002-0025	THE002-0025	THE002-0025
Tray	TRY254-0005	TRY254-0001	TRY315-0001	TRY385-0006	TRY387-0006	TRY505-0001	TRY507-0001
Tray holder	TRH254-0032	—	—	—	—	—	—
Feed water hose for ELC models	GAS084-0001	GAS084-0001	GAS084-0001	GAS084-0001	GAS084-0001	GAS084-0001	GAS084-0001
Compressed air hose (ELC models)	GAS084-0002	GAS084-0002	GAS084-0002	GAS084-0002	GAS084-0002	GAS084-0002	GAS084-0002
Drain hose for ELC models	GAS084-0007	GAS084-0007	GAS084-0007	GAS084-0007	GAS084-0007	GAS084-0007	GAS084-0007
Basket	—	BSK254-0006	BSK314-0005	BSK385-0002	BSK387-0006	BSK505-0002	BSK507-0010
Container	—	BSK254-0002	BSK314-0006	BSK385-0001	BSK387-0004	BSK505-0001	BSK507-0008